

NUMATICS®

NR & G Series

Rodless Cylinders



www.numatics.com

EMERSON
Industrial Automation

BCAE
Automation Solutions

青岛秉诚自动化设备有限公司
地址：中国·青岛市重庆南路99号海尔云街甲3号楼7F

服务热线：4006-918-365
网址：<http://www.ivalve.cc>

传真：(86-532)585-10-365
Email：sales@bechinas.com

NR & G Series

Features and Benefits	3
NR Series - How to Order	4
G Series - How To Order	5
NR Series – S1 Standard Carriage	6
NR Series - S1 Medium, Double Medium, Long, Double Long and Double Standard Carriages	7
NR Series - S5 Standard Carriage with Turcite Bearings	8
NR Series - S5 Fully Guided Medium, Double Medium, Long, Double Long and Double Standard Carriage	9
G Series - G1, Single Rail Medium Carriage	10
G Series – G1 Single Rail Long Carriage	11
G Series – G2 Twin Rail, Medium Carriage	12
G Series – G2 Twin Rail, Long Carriage	13
NR Series - S1 & S5 Mounting Plates	14
G Series - G1 & G2 Mounting Plate Location	15
G Series - G1 & G2 Mounting Plate Location	16
NR Series - S1 & S5 End Cap and Floating Mounting Brackets	17
NR Series - S5 Locking Unit	18
G Series - G1 & G2 Locking Unit	19
NR & G Series - Single End Supply, End of Stroke Shock Kit	20
NR Series - Stroke Adjustments Kits	21
G Series - Adjustable Stroke Kit	22
NR & G Series - End of Stroke Shock Brackets	23
Switch Mounting Kits	24
Rodless Cylinder Switch Mounting Kits	25
Sensing Part Numbers	26-28
Quick Disconnect Part Numbers	29
Service Kits and Accessories	30

Numatics NR & G Series Rodless Cylinders

Numatics, a world leader in air powered products and systems, offers an extensive range of rodless cylinders. Utilizing the most advanced design and production criteria, Numatics provides solutions for automation throughout all sectors of industry.

Specifications

Bore Sizes: 25, 32, 40, and 50 mm

Single Barrel Extrusions

Standard and Guided Carriages

Working Pressure: (min) 45 to 145 PSIG (max)

Ambient Temperature Range: -4°F to 175°F (-20°C to 80°C)

Medium: Filtered Air, with or without lubrication

Standard Stroke Lengths: Up to 19.5 ft. (6 meters)

Operating Speed: Up to 9.75 ft./sec. (3m/sec.)

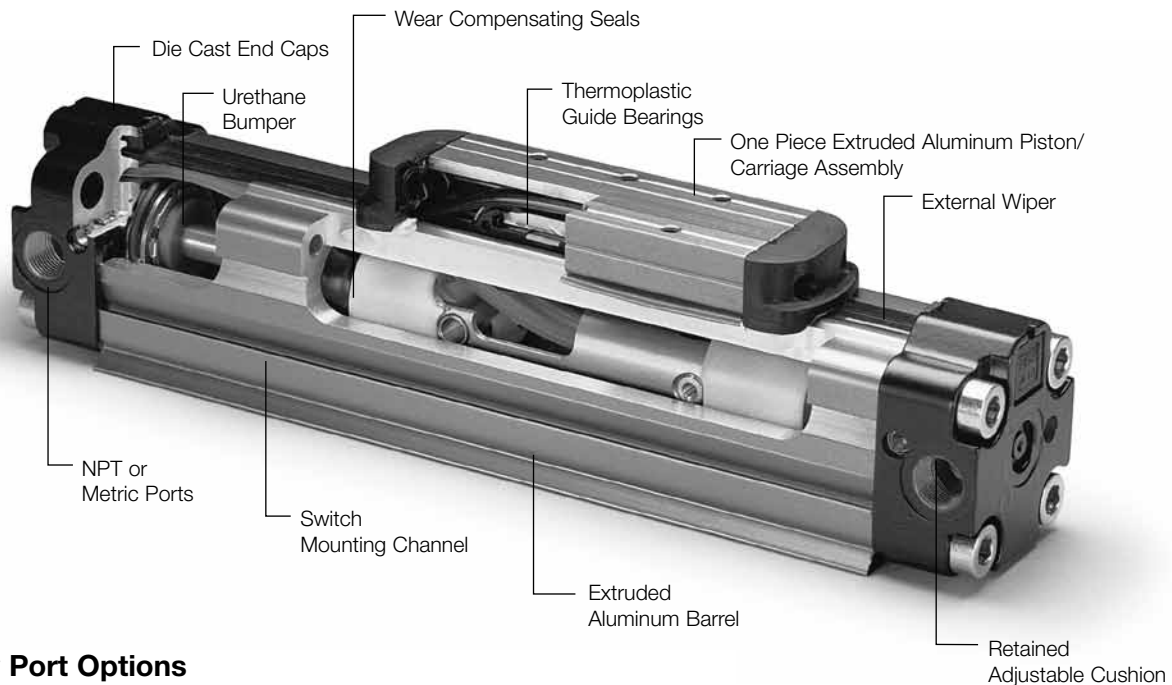
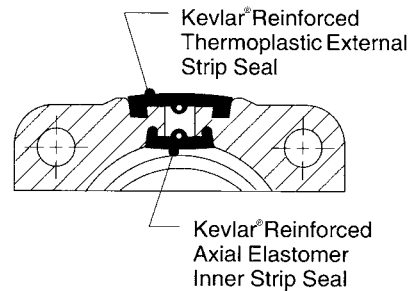

Supply Port Options

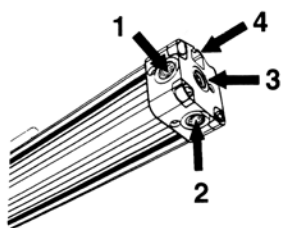

- 0 = No Supply Port (left end cap only when both chambers are supplied from the right end cap)
- 1 = Side
- 2 = Bottom
- 3 = Rear
- 4 = Both Chambers supplied from one end cap

Kevlar® is a registered trademark of DuPont.

NR Series - How to Order

S1 0 1 1 25 0048 E M O

Series

S1 = Single Barrel
S5 = Single Barrel with Integrated Turcite Bearing Guides

Carriage Type

0 = Standard
2 = Medium
3 = Long
4 = Double Standard
5 = Double Medium
6 = Double Long

Right End-Cap Supply Port

1 = Side Supply Port, NPT
2 = Bottom Supply Port, NPT
3 = Rear Supply Port, NPT
4 = Both Chambers Supplied from Right End-Cap, NPT
5 = Side Supply Port, G Tap
6 = Bottom Supply Port, G Tap
7 = Rear Supply Port, G Tap
8 = Both Chambers Supplied from Right End-Cap, G Tap

Left End-Cap Supply Port

0 = No Supply Port (When both chambers are supplied from right end-cap.)
1 = Side Supply Port, NPT
2 = Bottom Supply Port, NPT
3 = Rear Supply Port, NPT
5 = Side Supply Port, G Tap
6 = Bottom Supply Port, G Tap
7 = Rear Supply Port, G Tap

Cylinder Bore Sizes

25 = 25 Millimeters (1/8" Ports)
32 = 32 Millimeters (1/4" Ports)
40 = 40 Millimeters (3/8" Ports)
50 = 50 Millimeters (3/8" Ports)

Special Options
Reserved for Special Options

Sensing Type

M = Magnetic Carriage Only
O = No Magnet

Standard Cord (ALL switches come with mounting brackets - see page 24)

1 = Hall Effect PNP (Sourcing) - magnet sensing
2 = Hall Effect NPN (Sinking) - magnet sensing
3 = Reed Switch - magnet sensing

Quick Disconnect Switch***

Z = Hall Effect PNP (Sourcing) - magnet sensing
Y = Hall Effect NPN (Sinking) - magnet sensing
X = Reed Switch - magnet sensing
(***Cord to be purchased as separate item. Information found on page 25)
NOTE: Individual switch part numbers are on page 25)

Fractional Inches of Stroke
(If ordering stroke in millimeters, place letter "M" in this box.)

A = 0"
B = 1/8"
C = 1/4"
D = 3/8"
E = 1/2"
F = 5/8"
G = 3/4"
H = 7/8"
M = Millimeters

Full Inches or Millimeters of Stroke
(Note: This section requires four digits.)

0048 = 48" Stroke

Barrel Configurations

S1 Series

with Single Chamber

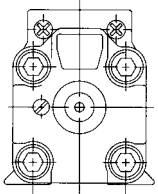

Single chamber bore sizes 25 mm to 50 mm in extruded aluminum alloy.
Standard stroke length up to 19.5 ft.
Various supply port configurations available.
Various carriage sizes.
High speed up to 9.75 ft./sec.

S5 Series

with Integrated Guides

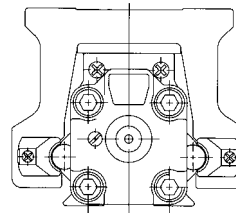

Turcite bearing system.
Speed capacity up to 5 ft./sec.
Available with locking unit.

Rodless Cylinder Theoretical Force Charts for NR & G Series

Single Barrel

Bore Diameter	Piston Area inches (mm)	Pressure PSIG (Bar)						
		20 (1.4)	40 (2.8)	60 (4.1)	80 (5.5)	100 (6.9)	120 (8.3)	145 (10.0)
25mm	0.76 (19.3)	15 (1.0)	30 (2.1)	46 (3.2)	61 (4.2)	76 (5.2)	91 (6.3)	110 (7.6)
32mm	1.25 (31.8)	25 (1.7)	50 (3.4)	75 (5.2)	100 (6.9)	125 (8.6)	150 (10.3)	181 (12.5)
40mm	1.95 (49.5)	39 (2.7)	78 (5.4)	117 (8.1)	156 (10.8)	195 (13.4)	234 (16.1)	283 (19.5)
50mm	3.04 (77.2)	61 (4.2)	122 (8.4)	182 (12.5)	243 (16.8)	304 (21.0)	365 (25.2)	441 (30.4)

G Series - How To Order

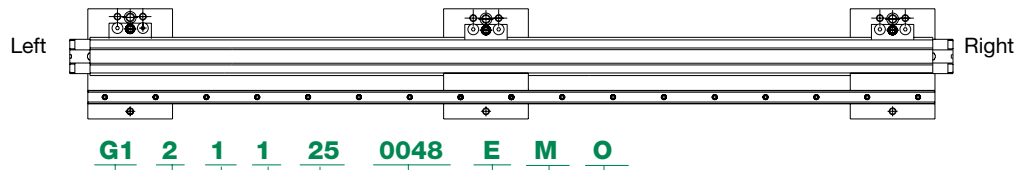

Series

- G1 = Single Barrel / Single Bearing Rail
- G2 = Single Barrel / Twin Bearing Rail

Carriage Type

- 2 = Medium Carriage
- 3 = Long Carriage
- 5 = Double Medium Carriage
- 6 = Double Long Carriage

Right End-Cap Supply Port

- 0 = No Supply Port (When Both Chambers are Supplied from the Left End-Cap)
- 1 = Side Supply Port, NPT
- 2 = Bottom Supply Port, NPT
- 3 = Rear Supply Port, NPT
- 4 = Both Chambers Supplied from the Right End-Cap, NPT
- 5 = Side Supply Port, G Tap
- 6 = Bottom Supply Port, G Tap
- 7 = Rear Supply Port, G Tap
- 8 = Both Chambers Supplied from the Right End-Cap, G Tap

Left End-Cap Supply Port

- 0 = No Supply Port (When Both Chambers Are Supplied from the Right End-Cap)
- 1 = Side Supply Port, NPT
- 2 = Bottom Supply Port, NPT
- 3 = Rear Supply Port, NPT
- 4 = Both Chambers Supplied from the Left End-Cap, NPT
- 5 = Side Supply Port, G Tap
- 6 = Bottom Supply Port, G Tap
- 7 = Rear Supply Port, G Tap
- 8 = Both Chambers Supplied from the Left End-Cap, G Tap

Cylinder Bore Size in Millimeters

- 25 = 25 Millimeters (1/8" Ports)
- 32 = 32 Millimeters (1/4" Ports)
- 40 = 40 Millimeters (3/8" Ports)
- 50 = 50 Millimeters (3/8" Ports)

Sensing Position & Other Options

- A = Single Position (one switch)
- B = Both Left & Right Position (two switches)
- O = No Sensing
- L = Lock Unit
- M = Lock Unit & One Switch
- N = Lock Unit & Two Switches

Sensing Type

- M = Magnetic Carriage Only
- O = No magnet

Standard Cord (ALL switches come with mounting brackets - see page 24)

- 1 = Hall Effect PNP (Sourcing) - magnet sensing
- 2 = Hall Effect NPN (Sinking) - magnet sensing
- 3 = Reed Switch - magnet sensing

Quick Disconnect Switch***

- Z = Hall Effect PNP (Sourcing) - magnet sensing
- Y = Hall Effect NPN (Sinking) - magnet sensing
- X = Reed Switch - magnet sensing

***Cord to be purchased as separate item.

Information found on page 25

NOTE: Individual switch part numbers are on page 25

Fractional Inches of Stroke

(If Ordering Cylinder Stroke in Millimeters, Place the Letter "M" in this Box)

- A = 0"
- B = 1/8"
- C = 1/4"
- D = 3/8"
- E = 1/2"
- F = 5/8"
- G = 3/4"
- H = 7/8"
- M = Millimeters

Full Inches or Millimeters of Stroke

(Note: This section requires four digits.)

- 0048 = 48" Stroke

Barrel Configurations

G1 Series

Single Rail Heavy Duty

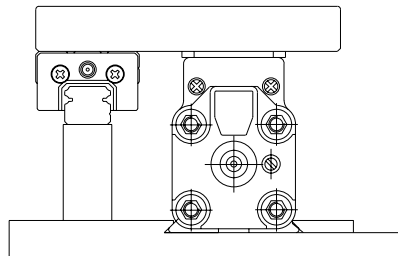

G2 Series

Twin Rail Super Heavy Duty

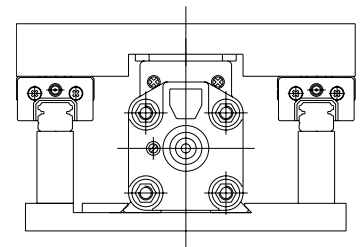

Single chamber bore sizes 25mm to 50mm in extruded aluminum alloy
Various supply port configurations available
Medium and long carriage types
High speed up to 9.75 ft./sec.

Dimensions: Inches (mm)

NR Series – S1 Standard Carriage (6 mounting holes)

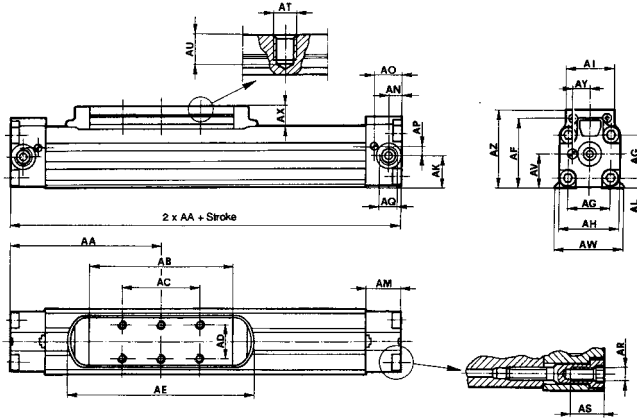

NOTE: In cases where the rodless cylinder is mounted onto external rigid guides, it is necessary to install the floating mounting bracket on the carriage.

Dia.	AA	AB	AC	AD	AE	AF	AG	AH	AI	AK	AL	AM	AN	AO	AP	AQ
25mm	3.94 (100.1)	3.74 (95.0)	1.97 (50.0)	0.94 (23.9)	5.12 (130.0)	1.89 (48.0)	1.10 (27.9)	1.59 (40.4)	1.30 (33.0)	0.79 (20.3)	0.28 (7.1)	0.94 (23.9)	0.29 (7.4)	0.72 (18.3)	0.23 (5.6)	1/8"
32mm	4.92 (125.0)	4.65 (118.1)	2.56 (65.0)	1.22 (31.0)	6.14 (156.0)	2.24 (56.9)	1.38 (35.1)	1.97 (50.0)	1.57 (39.9)	1.00 (25.4)	0.32 (8.1)	1.14 (29.0)	0.41 (10.4)	0.89 (22.6)	0.29 (7.4)	1/4"
40mm	5.91 (150.1)	5.28 (134.1)	2.56 (65.0)	1.22 (31.0)	6.97 (177.0)	2.91 (73.9)	1.72 (43.9)	2.52 (64.0)	1.73 (43.9)	1.33 (33.8)	0.47 (11.9)	1.30 (33.0)	0.49 (12.4)	1.04 (26.4)	0.34 (8.4)	3/8"
50mm	6.97 (177.0)	6.46 (164.1)	4.13 (104.9)	1.54 (39.1)	8.31 (211.1)	3.57 (90.7)	2.17 (55.1)	3.15 (80.0)	2.12 (53.8)	1.62 (41.4)	0.58 (14.7)	1.30 (33.0)	0.56 (14.2)	1.01 (25.7)	0.46 (11.7)	3/8"

Dia.	AR	AS	AT	AU	AV	AW	AX	AY	AZ	Weight lbs (kg) Stroke "0"	Increase in Pounds per inch of Stroke
25mm	M5	0.47 (11.9)	M5	0.35 (8.9)	0.90 (22.9)	1.69 (42.9)	0.63 (16.0)	0.48 (12.2)	2.27 (57.7)	1.56 (0.7)	0.12 (0.1)
32mm	M6	0.61 (15.5)	M6	0.35 (8.9)	1.10 (27.9)	2.15 (54.6)	0.63 (16.0)	0.56 (14.2)	2.61 (66.3)	2.86 (1.3)	0.18 (0.1)
40mm	M8	0.79 (20.1)	M6	0.43 (10.9)	1.46 (37.1)	2.64 (67.1)	0.77 (19.6)	0.65 (16.5)	3.38 (85.9)	5.49 (2.5)	0.31 (0.1)
50mm	M10	0.79 (20.1)	M8	0.47 (11.9)	1.88 (47.8)	3.39 (86.1)	0.81 (20.6)	0.75 (19.1)	4.06 (103.1)	10.56 (4.8)	0.54 (0.2)

Values of the static load; please note that in dynamic conditions, the load must be reduced due to effects associated with the speed. A moment is the product of the load (pounds) and the arm (inches), and the distance between the center of gravity of the load and the longitudinal axis of the piston.

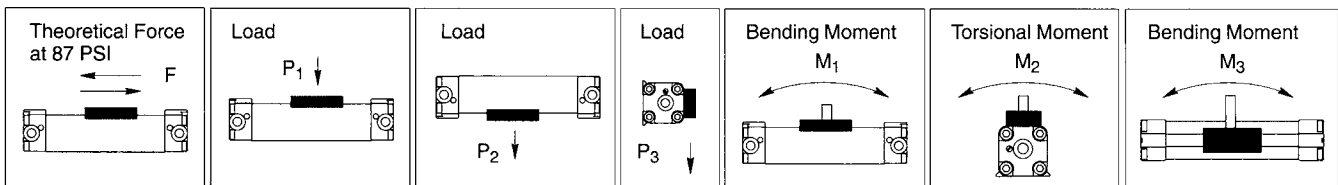

Diameter	F	P1	P2	P3	Std. Carriage			Medium Carriage			Long Carriage		
					M1	M2	M3	M1	M2	M3	M1	M2	M3
					in-lbs (Nm)			in-lbs (Nm)			in-lbs (Nm)		
25mm	66 (29.9)	70 (31.8)	70 (31.8)	25 (11.3)	88 (9.9)	16 (1.8)	66 (7.5)	104 (11.8)	18 (2.0)	88 (9.9)	125 (14.1)	18 (2.0)	106 (12.0)
32mm	109 (49.4)	112 (50.8)	112 (50.8)	40 (18.1)	117 (13.2)	38 (4.3)	132 (14.9)	200 (22.6)	40 (4.5)	160 (18.1)	260 (29.4)	42 (4.7)	180 (20.3)
40mm	170 (77.1)	134 (60.8)	134 (60.8)	50 (22.7)	265 (29.9)	65 (7.3)	195 (22.0)	310 (35.0)	65 (7.3)	210 (23.7)	442 (49.9)	70 (7.9)	228 (25.8)
50mm	265 (120.2)	180 (81.6)	180 (81.6)	65 (29.5)	531 (60.0)	99 (11.2)	245 (27.7)	580 (65.5)	99 (11.2)	280 (31.6)	784 (88.6)	110 (12.4)	310 (35.0)

Dimensions: Inches (mm)

NR Series - S1 Medium, Double Medium, Long, Double Long and Double Standard Carriages

Medium Carriage (6 mounting holes)

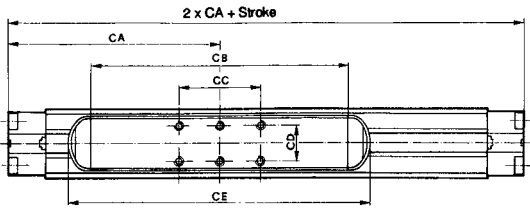

S1 Medium Carriage Dimensions

Diameter	CA	CB	CC	CD	CE	Weight lbs (kg) Stroke "0"
25mm	4.51 (114.6)	4.92 (125.0)	1.97 (50.0)	0.94 (23.9)	6.30 (160.0)	1.77 (0.8)
32mm	5.61 (142.5)	6.02 (152.9)	2.56 (65.0)	1.22 (31.0)	7.52 (191.0)	3.23 (1.5)
40mm	6.65 (168.9)	6.77 (172.0)	2.56 (65.0)	1.22 (31.0)	8.46 (214.9)	6.16 (2.8)
50mm	8.15 (207.0)	8.82 (224.0)	4.13 (104.9)	1.54 (39.1)	10.67 (271.0)	12.32 (5.6)

Double Medium Carriage

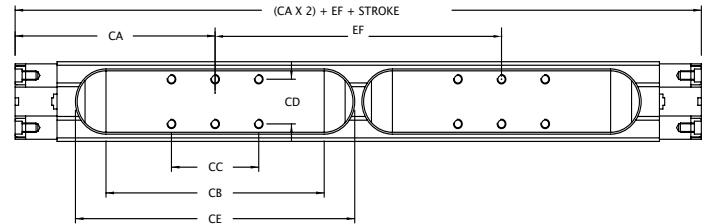

S1 Double Medium Carriage Dimensions

Diameter	CA	CB	CC	CD	CE	EF
25mm	4.51 (114.6)	4.92 (125.0)	1.97 (50.0)	0.94 (23.9)	6.30 (160.0)	6.46
32mm	5.61 (142.5)	6.02 (152.9)	2.56 (65.0)	1.22 (31.0)	7.52 (191.0)	8.11
40mm	6.65 (168.9)	6.77 (172.0)	2.56 (65.0)	1.22 (31.0)	8.46 (214.9)	9.57
50mm	8.15 (207.0)	8.82 (224.0)	4.13 (104.9)	1.54 (39.1)	10.67 (271.0)	12.44

Long Carriage (10 mounting holes)

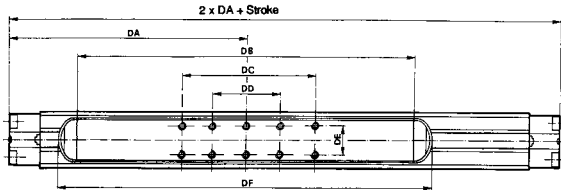

S1 Long Carriage Dimensions

Dia.	DA	DB	DC	DD	DE	DF	Weight lbs (kg) Stroke "0"
25mm	5.81 (147.6)	7.48 (190.0)	3.94 (100.1)	1.97 (50.0)	0.94 (23.9)	8.86 (225.0)	2.25 (1.0)
32mm	7.48 (190.0)	9.76 (247.9)	5.12 (130.0)	2.56 (65.0)	1.22 (31.0)	11.26 (286.0)	4.22 (1.9)
40mm	8.86 (225.0)	11.18 (284.0)	5.12 (130.0)	2.56 (65.0)	1.22 (31.0)	12.87 (326.9)	8.12 (3.7)
50mm	10.91 (277.1)	14.33 (364.0)	12.40 (315.0)	4.13 (104.9)	1.54 (39.1)	16.18 (411.0)	16.33 (7.4)

Double Long Carriage

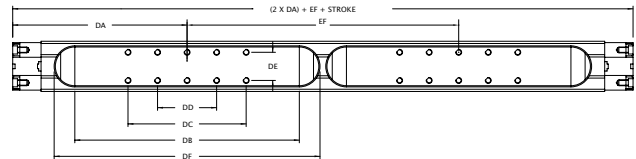

S1 Double Long Carriage Dimensions

Dia.	DA	DB	DC	DD	DE	DF	EF
25mm	5.81 (147.6)	7.48 (190.0)	3.94 (100.1)	1.97 (50.0)	0.94 (23.9)	8.86 (225.0)	9.05
32mm	7.48 (190.0)	9.76 (247.9)	5.12 (130.0)	2.56 (65.0)	1.22 (31.0)	11.26 (286.0)	11.80
40mm	8.86 (225.0)	11.18 (284.0)	5.12 (130.0)	2.56 (65.0)	1.22 (31.0)	12.87 (326.9)	13.95
50mm	10.91 (277.1)	14.33 (364.0)	12.40 (315.0)	4.13 (104.9)	1.54 (39.1)	16.18 (411.0)	17.95

Double Standard Carriage (6 mounting holes each carriage)

S1 Double Standard Carriage Dimensions

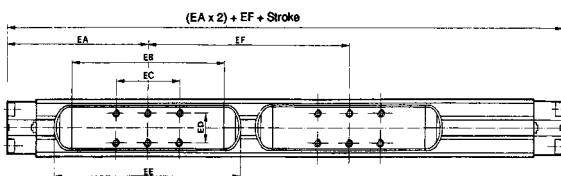

Diameter	EA	EB	EC	ED	EE	EF	Weight lbs (kg) Stroke "0"
25mm	3.94 (100.1)	3.74 (95.0)	1.97 (50.0)	0.95 (24.1)	5.12 (130.0)	5.28 (134.1)	2.50 (1.1)
32mm	4.92 (125.0)	4.73 (120.1)	2.56 (65.0)	1.22 (31.0)	6.18 (157.0)	6.73 (170.9)	4.61 (2.1)
40mm	5.91 (150.1)	5.28 (134.1)	2.56 (65.0)	1.22 (31.0)	6.97 (177.0)	8.07 (205.0)	8.89 (4.0)
50mm	6.97 (177.0)	6.46 (164.1)	4.13 (104.9)	1.54 (39.1)	8.70 (221.0)	10.08 (256.0)	17.64 (8.0)

Dimensions: Inches (mm)

NR Series - S5 Standard Carriage with Turcite Bearings (8 mounting holes)

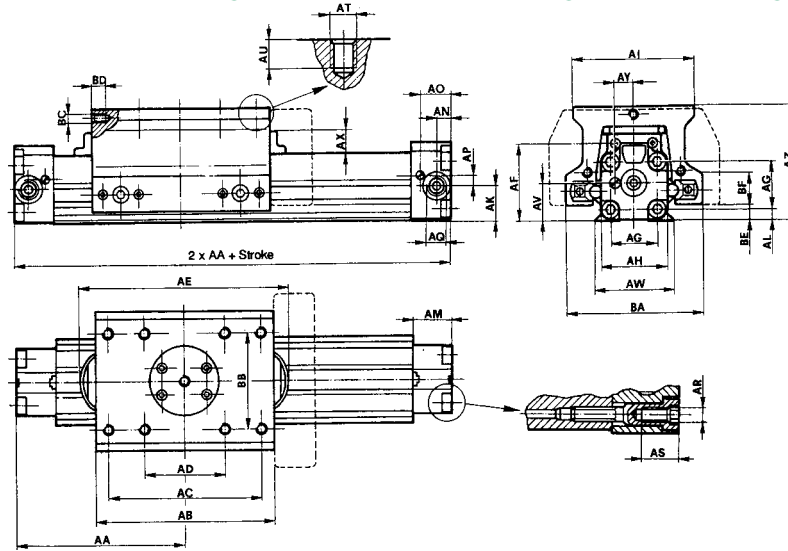

Dia.	AA	AB	AC	AD	AE	AF	AG	AH	AI	AK	AL	AM	AN	AO	AP	AQ	AR	AS
25mm	3.94 (100.1)	4.17 (105.9)	3.54 (89.9)	1.97 (50.0)	5.12 (130.0)	1.90 (48.3)	1.10 (27.9)	1.59 (40.4)	2.76 (70.1)	0.79 (20.3)	0.28 (7.1)	0.94 (23.9)	0.29 (7.4)	0.72 (18.3)	0.23 (5.6)	1/8"	M5	0.47 (11.9)
32mm	4.92 (125.0)	5.51 (140.0)	4.53 (115.1)	2.17 (55.1)	6.14 (156.0)	2.24 (56.9)	1.38 (35.1)	1.97 (50.0)	3.46 (87.9)	1.00 (25.4)	0.32 (8.1)	1.14 (29.0)	0.41 (10.4)	0.89 (22.6)	0.29 (7.4)	1/4"	M6	0.61 (15.5)
40mm	-	-	-	-	-	-	1.73 (43.9)	2.52 (64.0)	3.54 (89.9)	1.33 (33.8)	0.47 (11.9)	1.30 (33.0)	0.49 (12.4)	1.04 (26.4)	0.34 (8.4)	3/8"	M8	0.79 (20.1)
50mm	-	-	-	-	-	-	2.17 (55.1)	3.15 (80.0)	3.94 (100.1)	1.63 (41.4)	0.58 (14.7)	1.30 (33.0)	0.56 (14.2)	1.01 (25.7)	0.46 (11.7)	3/8"	M10	0.79 (20.1)

Dia.	AT	AU	AV	AW	AX	AY	AZ	BA	BB	BC	BD	BE	BF	Weight lbs (kg) Stroke "0"	Increase in Pounds Per Inch of Stroke
25mm	M6	0.39 (9.9)	0.90 (22.9)	1.69 (42.9)	0.63 (16.0)	0.48 (12.2)	2.83 (71.9)	3.35 (85.1)	1.97 (50.0)	M6	0.59 (15.0)	0.22 (5.6)	0.94 (23.9)	3.59 (1.6)	0.21 (0.1)
32mm	M8	0.47 (11.9)	1.10 (27.9)	2.24 (56.9)	0.63 (16.0)	0.56 (14.2)	3.25 (82.6)	3.94 (100.1)	2.66 (67.6)	M6	0.59 (15.0)	0.28 (7.1)	0.98 (24.9)	6.24 (2.8)	0.28 (0.1)
40mm	M8	0.55 (14.0)	1.46 (37.1)	2.64 (67.1)	0.77 (19.6)	0.65 (16.5)	4.20 (106.7)	5.31 (134.9)	2.56 (65.0)	M6	0.59 (15.0)	0.28 (7.1)	1.54 (39.1)	-	-
50mm	M8	0.63 (16.0)	1.88 (47.8)	3.39 (86.1)	0.81 (20.6)	0.75 (19.1)	4.87 (123.7)	5.87 (149.1)	3.01 (76.5)	M8	0.63 (16.0)	0.28 (7.1)	1.61 (40.9)	-	-

Values of the static load; please note that in dynamic conditions, the load must be reduced due to effects associated with the speed. A moment is the product of the load (pounds) and the arm (inches), and the distance between the center of gravity of the load and the longitudinal axis of the piston.

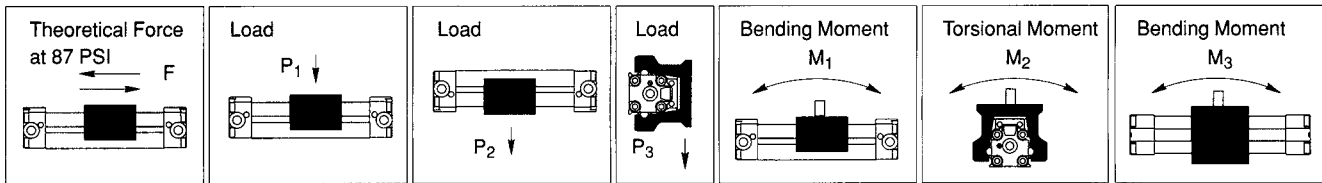

Diameter	F	P1	P2	P3	Std. Carriage			Medium Carriage			Long Carriage		
					M1	M2	M3	M1	M2	M3	M1	M2	M3
					lbs (kg)			in-lbs (Nm)			in-lbs (Nm)		
25mm	66 (29.9)	90 (40.8)	90 (40.8)	63 (28.6)	150 (16.9)	78 (8.8)	239 (27.0)	203 (22.9)	78 (8.8)	301 (34.0)	318 (35.9)	78 (8.8)	460 (52.0)
32mm	109 (49.4)	90 (40.8)	90 (40.8)	63 (28.6)	212 (24.0)	96 (10.8)	327 (36.9)	274 (31.0)	96 (10.8)	407 (46.0)	442 (49.9)	96 (10.8)	637 (72.0)
40mm	170 (77.1)	101 (45.8)	101 (45.8)	112 (50.8)	N/A	N/A	N/A	363 (41.0)	146 (16.5)	884 (99.9)	593 (67.0)	146 (16.5)	1327 (149.9)
50mm	265 (120.2)	101 (45.8)	101 (45.8)	112 (50.8)	N/A	N/A	N/A	769 (86.9)	177 (20.0)	1106 (125.0)	852 (96.3)	177 (20.0)	

Dimensions: Inches (mm)

NR Series - S5 Fully Guided Medium, Double Medium, Long, Double Long and Double Standard Carriage

Medium Carriage (8 mounting holes)

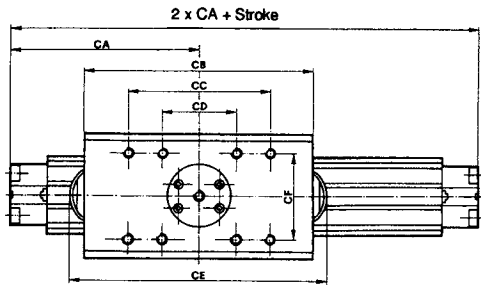

S5 Medium Carriage Dimensions

Dia.	CA	CB	CC	CD	CE	CF	Weight lbs (kg) Stroke "0"
25mm	4.51 (114.6)	5.35 (135.9)	3.54 (89.9)	1.97 (50.0)	6.30 (160.0)	1.97 (50.0)	3.97 (1.8)
32mm	5.61 (142.5)	6.89 (175.0)	4.53 (115.1)	2.17 (55.1)	7.52 (191.0)	2.66 (67.6)	7.35 (3.3)
40mm	6.65 (168.9)	8.07 (205.0)	7.09 (180.1)	2.95 (74.9)	8.46 (214.9)	2.56 (65.0)	13.23 (6.0)
50mm	8.15 (207.0)	10.16 (258.1)	7.48 (190.0)	3.15 (80.0)	10.67 (271.0)	3.01 (76.5)	21.93 (9.9)

Double Medium Carriage

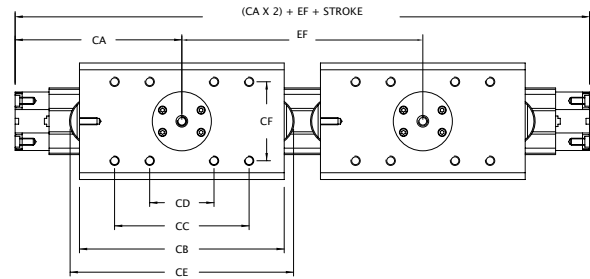

S5 Double Medium Carriage Dimensions

Dia.	CA	CB	CC	CD	CE	CF	EF
25mm	4.51 (114.6)	5.35 (135.9)	3.54 (89.9)	1.97 (50.0)	6.30 (160.0)	1.97 (50.0)	6.46
32mm	5.61 (142.5)	6.89 (175.0)	4.53 (115.1)	2.17 (55.1)	7.52 (191.0)	2.66 (67.6)	8.11
40mm	6.65 (168.9)	8.07 (205.0)	7.09 (180.1)	2.95 (74.9)	8.46 (214.9)	2.56 (65.0)	9.57
50mm	8.15 (207.0)	10.16 (258.1)	7.48 (190.0)	3.15 (80.0)	10.67 (271.0)	3.01 (76.5)	12.44

Long Carriage (12 mounting holes)

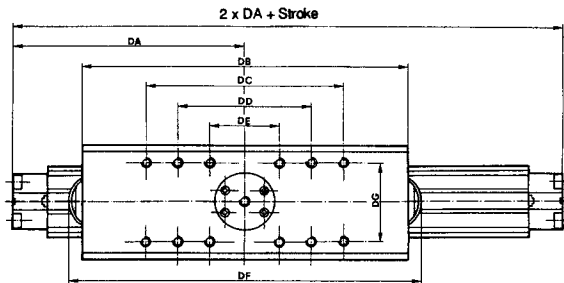

S5 Long Carriage Dimensions

Dia.	DA	DB	DC	DD	DE	DF	DG	Weight lbs (kg) Stroke "0"
25mm	5.81 (147.6)	7.91 (200.9)	5.12 (130.0)	3.54 (89.9)	1.97 (50.0)	8.86 (225.0)	1.97 (50.0)	5.78 (2.6)
32mm	7.48 (190.0)	10.63 (270.0)	6.89 (175.0)	4.53 (115.1)	2.17 (55.1)	11.26 (286.0)	2.66 (67.6)	10.35 (4.7)
40mm	8.86 (225.0)	12.48 (317.0)	11.02 (279.9)	7.28 (184.9)	2.95 (74.9)	12.87 (326.9)	2.56 (65.0)	18.60 (8.4)
50mm	10.91 (277.1)	15.67 (398.0)	12.60 (320.0)	7.87 (199.9)	3.15 (80.0)	16.18 (411.0)	3.01 (76.5)	30.65 (13.9)

Double Long Carriage

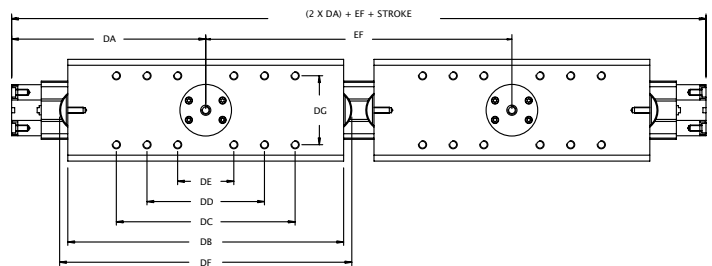

S5 Double Long Carriage Dimensions

Dia.	DA	DB	DC	DD	DE	DF	DG	EF
25mm	5.81 (147.6)	7.91 (200.9)	5.12 (130.0)	3.54 (89.9)	1.97 (50.0)	8.86 (225.0)	1.97 (50.0)	9.05
32mm	7.48 (190.0)	10.63 (270.0)	6.89 (175.0)	4.53 (115.1)	2.17 (55.1)	11.26 (286.0)	2.66 (67.6)	11.80
40mm	8.86 (225.0)	12.48 (317.0)	11.02 (279.9)	7.28 (184.9)	2.95 (74.9)	12.87 (326.9)	2.56 (65.0)	13.95
50mm	10.91 (277.1)	15.67 (398.0)	12.60 (320.0)	7.87 (199.9)	3.15 (80.0)	16.18 (411.0)	3.01 (76.5)	17.95

Double Standard Carriage 25-32 mm Diameter; (8 mounting holes each carriage)

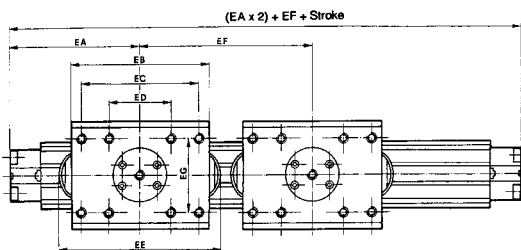

S5 Double Standard

Diameter		EA	EB	EC	ED	EE	EF	EG	Weight lbs (kg) Stroke "0"
Standard	25mm	3.94 (100.1)	4.17 (105.9)	3.54 (89.9)	1.97 (50.0)	5.12 (130.0)	5.28 (134.1)	1.97 (50.0)	6.49 (2.6)
Standard	32mm	4.92 (125.0)	5.51 (140.0)	4.53 (115.1)	2.17 (55.1)	6.18 (157.0)	6.73 (170.9)	2.66 (67.6)	11.31 (5.1)

Dimensions: Inches (mm)

G Series - G1, Single Rail Medium Carriage

Medium Carriage

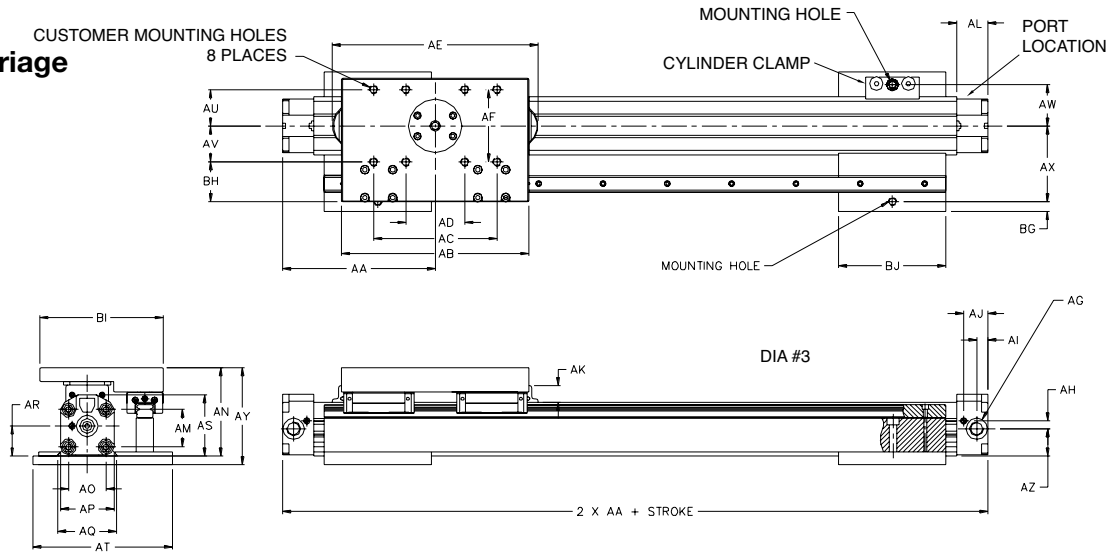

Note: Port location indicated on diagram #3 is for clarification purposes only

Diameter	AA	AB	AC	AD	AE	AF	AG	AH	AI	AJ	AK	AL	AM	AN	AO
25mm	4.51 (114.6)	5.35 (135.9)	3.54 (89.9)	1.97 (50.0)	6.30 (160.0)	1.97 (50.0)	1/8	0.23 (5.8)	0.29 (7.4)	0.72 (18.3)	0.61 (15.5)	0.94 (23.9)	1.10 (27.9)	2.77 (70.4)	1.10 (27.9)
32mm	5.61 (142.5)	6.89 (175.0)	4.53 (115.1)	2.17 (55.1)	7.56 (192.0)	2.66 (67.6)	1/4	0.29 (7.4)	0.41 (10.4)	0.89 (22.6)	0.61 (15.5)	1.14 (29.0)	1.38 (35.1)	3.09 (78.5)	1.38 (35.1)
40mm	6.65 (168.9)	8.07 (204.9)	7.09 (180.1)	2.95 (74.9)	8.46 (214.9)	2.56 (65.0)	3/8	0.33 (8.4)	0.49 (12.5)	1.04 (26.4)	0.74 (18.8)	1.30 (33.0)	1.72 (43.7)	3.94 (100.1)	1.72 (43.7)
50mm	8.15 (207.0)	10.16 (258.1)	7.48 (190.0)	3.15 (80.0)	11.06 (280.9)	3.94 (100.1)	3/8	0.46 (11.7)	0.56 (14.2)	1.01 (25.7)	0.77 (19.6)	1.30 (33.0)	2.17 (55.2)	4.75 (120.7)	2.17 (55.1)
Diameter	AP	AQ	AR	AS	AT	AU	AV	AW	AX	AY	AZ	BG	BH	BI	BJ
25mm	1.59 (40.4)	1.69 (42.9)	0.89 (22.6)	1.73 (43.9)	5.12 (130.1)	0.98 (24.9)	0.98 (24.9)	1.22 (31.0)	2.55 (64.8)	3.24 (82.3)	0.79 (20.1)	0.35 (8.9)	1.57 (39.8)	3.94 (100.1)	3.94 (100.1)
32mm	1.97 (50.0)	2.15 (54.6)	1.10 (27.9)	2.09 (53.1)	5.12 (130.1)	1.33 (33.8)	1.33 (33.8)	1.51 (38.4)	2.78 (70.6)	3.56 (90.4)	1.00 (25.4)	0.35 (8.9)	1.46 (37.1)	4.53 (115.1)	3.94 (100.1)
40mm	2.52 (64.0)	2.64 (67.1)	1.46 (37.1)	2.70 (68.6)	6.59 (167.4)	0.69 (17.5)	1.87 (47.5)	1.89 (48.0)	3.11 (79.0)	4.55 (115.6)	1.34 (34.0)	0.41 (10.4)	1.18 (29.1)	4.92 (125.0)	4.72 (119.9)
50mm	3.15 (80.0)	3.39 (86.1)	1.87 (47.5)	3.35 (85.1)	6.59 (167.4)	1.00 (25.4)	2.93 (74.4)	2.26 (57.4)	3.48 (88.4)	5.36 (136.1)	1.63 (41.4)	0.41 (10.4)	0.49 (12.5)	4.92 (125.0)	4.72 (119.9)

Moment ratings are static. To properly apply any rodless cylinder velocity, load and cylinder orientation, pressure and stroke length must also be included in the calculation of dynamic moments. The Numatics NR Sizer program can perform these calculations.

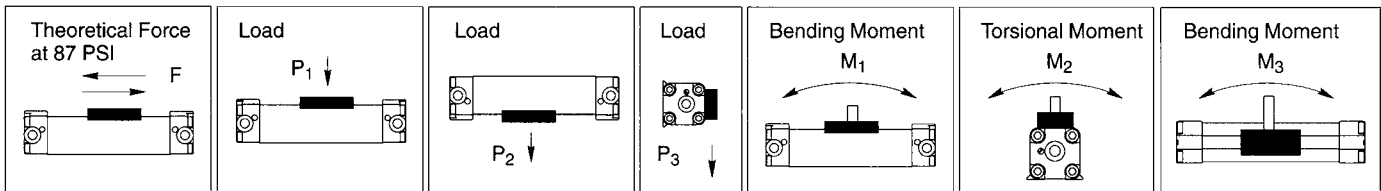

Medium Carriage Diameter	P1	P2 lbs (kg)	P3	M1 Pitching	M2 Rolling in-lbs (Nm)	M3 Yawing	Long Carriage Diameter	P1	P2 lbs (kg)	P3	M1 Pitching	M2 Rolling	M3 Yawing
25mm	331 (150.1)	265 (120.2)	463 (210.0)	2,558 (289.0)	618 (69.8)	2,558 (289.0)	25mm	496 (225.0)	397 (180.1)	695 (315.2)	4,895 (553.1)	926 (104.6)	4,895 (553.1)
32mm	331 (150.1)	265 (120.2)	359 (162.8)	3,439 (388.6)	618 (69.8)	3,087 (348.8)	32mm	496 (225.0)	397 (180.1)	535 (242.7)	7,496 (847.0)	926 (104.6)	7,496 (847.0)
40mm	805 (365.1)	651 (295.3)	1,235 (560.2)	9,701 (1096.2)	1,940 (219.2)	9,701 (1096.2)	40mm	1,207 (547.5)	976 (442.7)	1,852 (840.1)	23,810 (2690.4)	2,910 (328.8)	23,810 (2690.1)
50mm	673 (305.3)	607 (275.3)	651 (295.3)	17,196 (1943.1)	1,940 (219.2)	17,196 (1943.1)	50mm	1,009 (457.7)	910 (412.8)	976 (442.7)	29,542 (3338.1)	2,910 (328.8)	29,983 (3387.9)

Dimensions: Inches (mm)

G Series – G1 Single Rail Long Carriage

Long Carriage

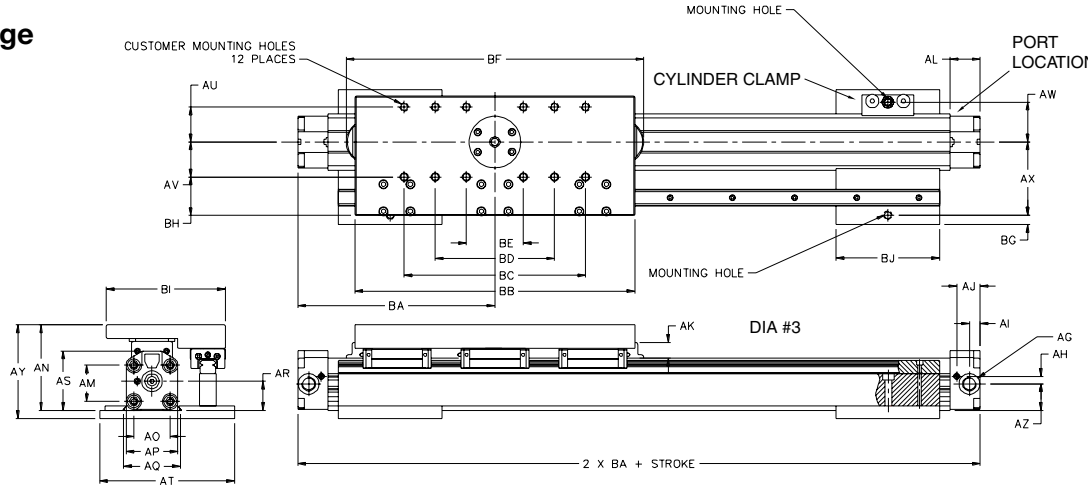

Note: Port location indicated on diagram #3 is for clarification purposes only

Diameter	AG	AH	AI	AJ	AK	AL	AM	AN	AO	AP	AQ	AR	AS	AT	AU
25mm	1/8	0.23 (5.8)	0.29 (7.4)	0.72 (18.3)	0.61 (15.5)	0.94 (23.9)	1.10 (27.9)	2.77 (70.4)	1.10 (27.9)	1.59 (40.4)	1.69 (42.9)	0.89 (22.6)	1.73 (43.9)	5.12 (130.1)	0.98 (24.9)
32mm	1/4	0.29 (7.4)	0.41 (10.4)	0.89 (22.8)	0.61 (15.5)	1.14 (29.0)	1.38 (35.1)	3.00 (78.5)	1.38 (35.1)	1.97 (50.0)	2.15 (54.6)	1.10 (27.9)	2.09 (53.1)	5.12 (130.1)	1.33 (33.8)
40mm	3/8	0.33 (8.4)	0.49 (12.5)	1.04 (26.4)	0.74 (18.0)	1.30 (33.0)	1.72 (43.6)	3.94 (100.1)	1.72 (43.7)	2.52 (64.0)	2.64 (67.1)	1.46 (37.1)	2.70 (68.6)	6.59 (167.4)	0.69 (17.5)
50mm	3/8	0.46 (11.7)	0.58 (14.2)	1.01 (25.7)	0.77 (19.6)	1.30 (33.0)	2.17 (55.2)	4.75 (120.7)	2.17 (55.1)	3.15 (80.0)	3.39 (86.1)	1.87 (47.5)	3.35 (85.1)	6.59 (167.4)	1.00 (25.4)
Diameter	AV	AW	AX	AY	AZ	BA	BB	BC	BD	BE	BF	BG	BH	BI	BJ
25mm	0.98 (24.89)	1.22 (30.99)	2.55 (64.8)	3.24 (82.3)	0.79 (20.1)	5.01 (127.6)	7.91 (200.9)	5.12 (130.0)	3.54 (89.9)	1.97 (50.0)	8.86 (225.0)	0.35 (8.9)	1.57 (39.8)	3.94 (100.1)	3.94 (100.1)
32mm	1.33 (33.78)	1.51 (38.35)	2.78 (70.6)	3.56 (90.4)	1.00 (25.4)	7.48 (189.0)	10.63 (270.0)	6.89 (175.0)	4.53 (115.1)	2.17 (55.1)	11.30 (287.0)	0.35 (8.9)	1.46 (37.1)	4.53 (115.1)	3.94 (100.1)
40mm	1.87 (47.50)	1.89 (48.01)	3.11 (79.0)	4.55 (115.6)	1.34 (34.0)	8.86 (225.0)	12.48 (317.0)	11.02 (279.9)	7.28 (184.9)	2.95 (74.9)	12.87 (326.9)	0.41 (10.4)	1.18 (29.1)	4.92 (125.0)	4.72 (119.9)
50mm	2.93 (74.42)	2.26 (57.40)	3.48 (88.4)	5.36 (136.1)	1.63 (41.4)	10.91 (277.1)	15.67 (398.0)	12.60 (320.0)	7.87 (199.9)	3.15 (80.0)	16.57 (420.9)	0.41 (10.4)	0.49 (12.5)	4.92 (125.0)	4.72 (119.9)

Base Mounting Hole

Carriage Mounting Hole

Diameter	For Med/Long Carriage	Diameter	For Med/Long Carriage
25mm	M8x1.25	25mm	M6x1
32mm	M8x1.25	32mm	M8x1.25
40mm	M10x1.50	40mm	M8x1.25
50mm	M10x1.50	50mm	M8x1.25

Tolerance for stroke
± 1.57 mm

Bearing Rail Length Formula

For 25/32 Bore Sizes

$$\text{Bearing Rail Length} = \left(\frac{\text{Stroke} + C}{60} \right) \times 60 + 40$$

Round down () to nearest whole number • Stroke is in millimeters

25mm Medium Carriage	C = 181
25mm Long Carriage	C = 247
32mm Medium Carriage	C = 227
32mm Long Carriage	C = 322

For 40/50 Bore Sizes

$$\text{Bearing Rail Length} = \left(\frac{\text{Stroke} + C}{60} \right) \times 60$$

Round down () to nearest whole number • Stroke is in millimeters

40mm Medium Carriage	C = 272
40mm Long Carriage	C = 384
50mm Medium Carriage	C = 348
50mm Long Carriage	C = 488

Dimensions: Inches (mm)

G Series – G2 Twin Rail, Medium Carriage

Medium Carriage

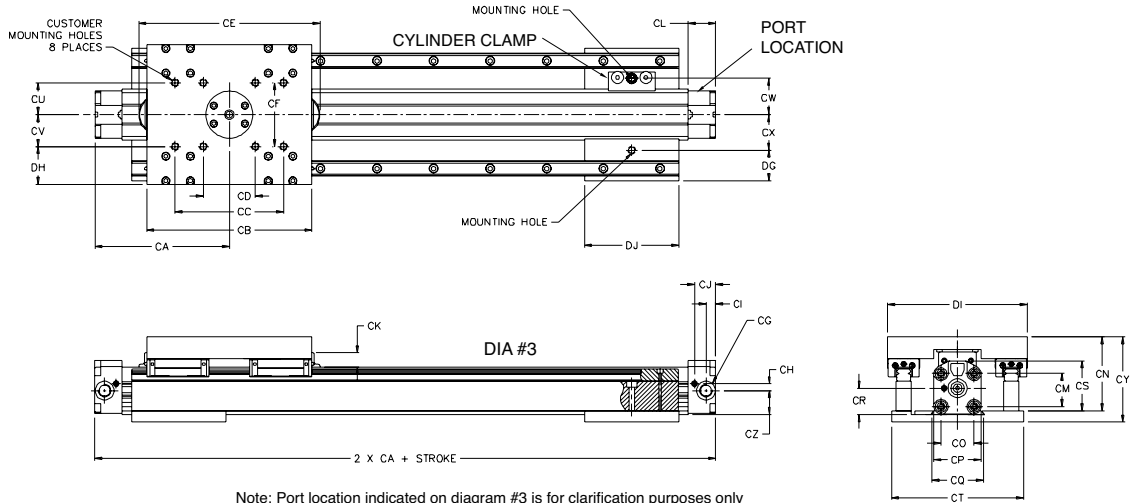

Note: Port location indicated on diagram #3 is for clarification purposes only

Diameter	CA	CB	CC	CD	CE	CF	CG	CH	CI	CJ	CK	CL	CM	CN	CO
25mm	4.51 (114.6)	5.35 (135.9)	3.54 (89.9)	1.97 (50.0)	6.30 (160.0)	1.97 (50.0)	1/8	0.23 (5.8)	0.29 (7.4)	0.72 (18.3)	0.61 (15.5)	0.94 (23.9)	1.10 (27.9)	2.77 (70.4)	1.10 (27.9)
32mm	5.61 (142.5)	6.89 (175.0)	4.53 (115.1)	2.17 (55.1)	7.56 (192.0)	2.66 (67.6)	1/4	0.29 (7.4)	0.41 (10.4)	0.89 (22.6)	0.61 (15.5)	1.14 (29.0)	1.38 (35.1)	3.09 (78.5)	1.38 (35.1)
40mm	6.65 (168.9)	8.07 (205.0)	7.09 (180.1)	2.95 (74.9)	8.46 (214.9)	2.56 (65.0)	3/8	0.33 (8.4)	0.49 (12.5)	1.04 (26.4)	0.74 (18.8)	1.30 (33.0)	1.72 (43.7)	3.94 (100.1)	1.72 (43.7)
50mm	8.15 (207.0)	10.16 (258.1)	7.48 (190.0)	3.15 (80.0)	11.06 (280.9)	3.94 (100.1)	3/8	0.46 (11.7)	0.56 (14.2)	1.01 (25.7)	0.77 (19.6)	1.30 (33.0)	2.17 (55.2)	4.75 (120.7)	2.17 (55.1)

Diameter	CP	CQ	CR	CS	CT	CU	CV	CW	CX	CY	CZ	DG	DH	DI	DJ
25mm	1.59 (40.4)	1.69 (42.9)	0.89 (22.6)	1.73 (43.9)	5.51 (140.0)	0.98 (24.9)	0.98 (24.9)	1.19 (30.2)	1.25 (31.8)	3.24 (82.3)	0.79 (20.1)	1.28 (32.5)	1.70 (43.2)	5.83 (148.1)	3.94 (100.1)
32mm	1.97 (50.0)	2.15 (54.6)	1.10 (27.9)	2.09 (53.1)	5.51 (140.0)	1.33 (33.8)	1.33 (33.8)	1.51 (38.4)	1.48 (37.6)	3.56 (90.4)	1.00 (25.4)	1.24 (32.5)	1.58 (40.1)	5.83 (148.1)	3.94 (100.1)
40mm	2.52 (64.0)	2.64 (67.1)	1.46 (37.1)	2.70 (68.6)	8.46 (214.9)	1.65 (41.9)	0.91 (23.1)	1.89 (48.0)	1.89 (48.0)	4.55 (115.6)	1.34 (34.0)	1.97 (50.0)	2.95 (74.9)	8.46 (214.9)	4.72 (119.9)
50mm	3.15 (80.0)	3.39 (86.1)	1.87 (47.5)	3.35 (85.1)	8.46 (214.9)	1.97 (50.0)	1.97 (50.0)	2.26 (57.4)	2.26 (57.4)	5.36 (136.1)	1.63 (41.4)	1.97 (50.0)	2.26 (57.4)	8.46 (214.9)	4.72 (119.9)

Moment ratings are static. To properly apply any rodless cylinder velocity, load and cylinder orientation, pressure and stroke length must also be included in the calculation of dynamic moments. The Numatics NR Sizer program can perform these calculations.

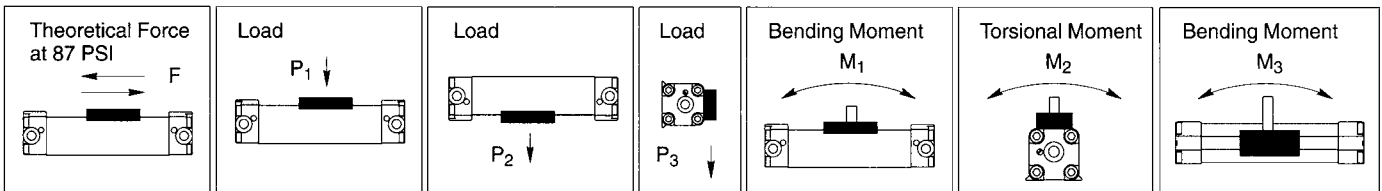

Medium Carriage Diameter	P1	P2 lbs (kg)	P3	M1 Pitching	M2 Rolling in-lbs (Nm)	M3 Yawing	Long Carriage Diameter	P1	P2 lbs (kg)	P3	M1 Pitching	M2 Rolling in-lbs (Nm)	M3 Yawing
25mm	5,512 (2500.2)	4,145 (1880.1)	3,528 (1600.3)	14,771 (1669.0)	7,937 (896.8)	12,567 (1420.0)	25mm	8,268 (3750.3)	6,217 (2820.0)	5,291 (2400.0)	25,574 (2889.7)	11,905 (1345.2)	21,826 (2466.2)
32mm	5,512 (2500.2)	4,145 (1880.1)	3,528 (1600.3)	21,826 (2466.0)	7,937 (896.8)	18,519 (2092.5)	32mm	8,268 (3750.3)	6,217 (2820.0)	5,291 (2400.0)	35,495 (4010.7)	11,905 (1345.2)	30,204 (3412.9)
40mm	11,464 (5200.0)	8,422 (3820.2)	7,077 (3210.1)	42,770 (4832.8)	22,487 (2540.9)	35,715 (4035.6)	40mm	17,196 (7800.0)	12,633 (5730.2)	10,616 (4815.3)	89,288 (10089.0)	33,951 (3836.3)	74,957 (8469.7)
50mm	11,464 (5200.0)	8,422 (3820.2)	7,077 (3210.1)	67,903 (7672.7)	22,487 (2540.9)	57,100 (6452.0)	50mm	17,196 (7800.0)	12,633 (5730.2)	10,616 (4815.3)	110,452 (12480.5)	33,951 (3836.3)	92,815 (10487.6)

Dimensions: Inches (mm)

G Series – G2 Twin Rail, Long Carriage

Long Carriage

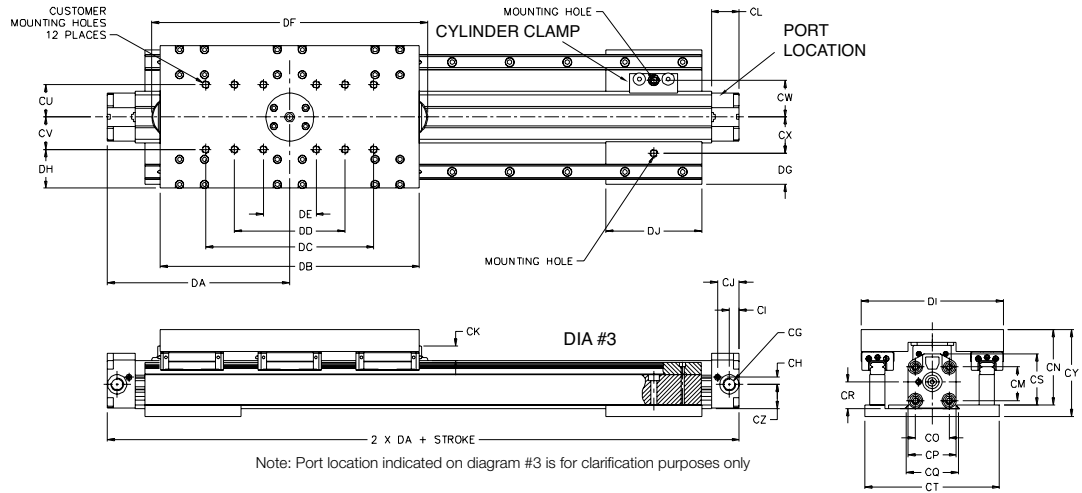

Diameter	CG	CH	CI	CJ	CK	CL	CM	CN	CO	CP	CQ	CR	CS	CT	CU
25mm	1/8 (5.8)	0.23 (5.8)	0.29 (7.4)	0.72 (18.3)	0.61 (15.5)	0.94 (23.9)	1.10 (27.9)	2.77 (70.7)	1.10 (27.9)	1.59 (40.4)	1.69 (42.9)	0.89 (22.6)	1.73 (43.9)	5.51 (140.0)	0.98 (24.9)
32mm	1/4 (7.4)	0.29 (7.4)	0.41 (10.4)	0.89 (22.8)	0.61 (15.5)	1.14 (29.0)	1.38 (35.1)	3.00 (78.5)	1.38 (35.1)	1.97 (50.0)	2.15 (54.6)	1.10 (27.9)	2.09 (53.1)	5.51 (140.0)	1.33 (33.8)
40mm	3/8 (8.4)	0.33 (8.4)	0.49 (12.5)	1.04 (26.4)	0.74 (18.0)	1.30 (33.0)	1.72 (43.6)	3.94 (100.1)	1.72 (43.7)	2.52 (64.0)	2.64 (67.1)	1.46 (37.1)	2.70 (68.6)	8.46 (214.9)	1.65 (41.9)
50mm	3/8 (11.7)	0.46 (11.7)	0.58 (14.2)	1.01 (25.7)	0.77 (19.6)	1.30 (33.0)	2.17 (55.2)	4.75 (120.7)	2.17 (55.1)	3.15 (80.0)	3.39 (86.1)	1.87 (47.5)	3.35 (85.1)	8.46 (214.9)	1.97 (50.0)

Diameter	CV	CW	CX	CY	CZ	DA	DB	DC	DD	DE	DF	DG	DH	DI	DJ
25mm	0.98 (24.89)	1.19 (30.2)	1.25 (31.8)	3.24 (82.3)	0.79 (20.1)	5.81 (147.6)	7.88 (200.2)	5.12 (130.0)	3.54 (89.9)	1.97 (50.0)	8.86 (225.0)	1.28 (32.5)	1.70 (43.2)	5.83 (148.1)	3.94 (100.1)
32mm	1.33 (33.78)	1.51 (38.35)	1.46 (37.6)	3.56 (90.4)	1.00 (25.4)	7.48 (190.0)	10.63 (270.0)	6.89 (175.0)	4.53 (115.1)	2.17 (55.1)	11.30 (287.0)	1.28 (32.5)	1.58 (40.1)	5.83 (148.1)	3.94 (100.1)
40mm	0.91 (23.1)	1.89 (48.01)	1.89 (48.0)	4.55 (115.6)	1.34 (34.0)	8.86 (225.0)	12.48 (317.0)	11.02 (279.9)	7.28 (184.9)	2.95 (74.9)	12.87 (326.9)	1.97 (50.0)	2.95 (74.9)	8.46 (214.9)	4.72 (119.9)
50mm	1.97 (50.0)	2.26 (57.4)	2.26 (57.4)	5.36 (136.1)	1.63 (41.4)	10.91 (277.1)	15.67 (398.0)	12.59 (319.8)	7.86 (199.6)	3.15 (80.0)	16.57 (420.9)	1.97 (50.0)	2.26 (57.4)	8.46 (214.9)	4.72 (119.9)

Base Mounting Hole

Carriage Mounting Hole

Diameter	For Med/Long Carriage	Diameter	For Med/Long Carriage
25mm	M8x1.25	25mm	M6x1
32mm	M8x1.25	32mm	M8x1.25
40mm	M10x1.50	40mm	M8x1.25
50mm	M10x1.50	50mm	M8x1.25

Tolerance for stroke
± 1.57 mm

Bearing Rail Length Formula

For 25/32 Bore Sizes

$$\text{Bearing Rail Length} = \left(\frac{\text{Stroke} + C}{60} \right) \times 60 + 40$$

Round down () to nearest whole number • Stroke is in millimeters

25mm Medium Carriage	C = 181
25mm Long Carriage	C = 247
32mm Medium Carriage	C = 227
32mm Long Carriage	C = 322

For 40/50 Bore Sizes

$$\text{Bearing Rail Length} = \left(\frac{\text{Stroke} + C}{60} \right) \times 60$$

40mm Medium Carriage	C = 272
40mm Long Carriage	C = 384
50mm Medium Carriage	C = 348
50mm Long Carriage	C = 488

Dimensions: Inches (mm)

NR Series - S1 & S5 Mounting Plates

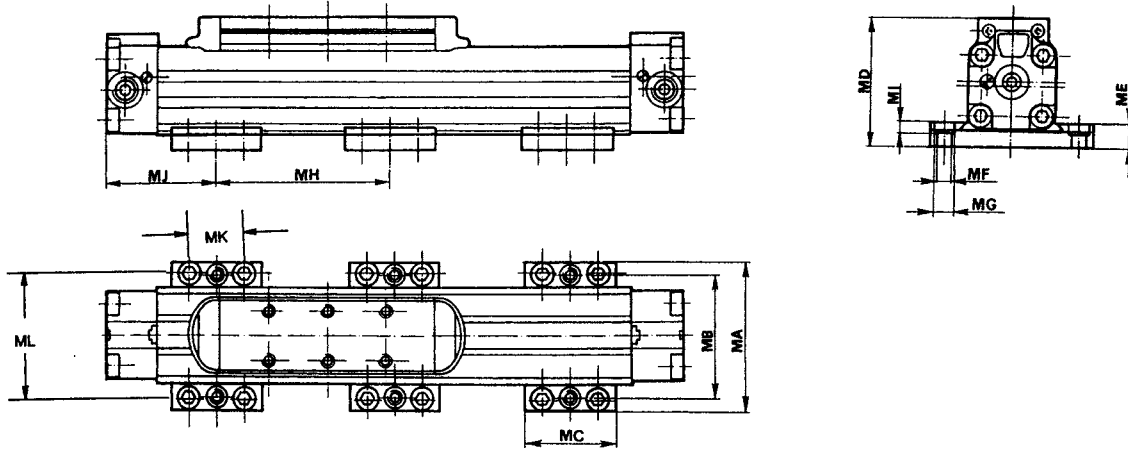

Diameter	MA	MB	MC	S1 MD	S5 MD	ME	MF	MG	MH*	MI	MJ	MK	ML	Weight lbs (kg) Stroke "0"	Ordering Code
25mm	3.09 (78.5)	2.50 (63.5)	1.97 (50.0)	2.58 (65.5)	3.14 (79.8)	0.47 (11.9)	25mm M8x1.25	0.43 (10.9)	19.69* (500.1)	0.26 (6.6)	2.17 (55.1)	1.18 (30.0)	2.58 (65.5)	0.68 (0.3)	SF-12025
32mm	3.62 (91.9)	3.05 (77.5)	1.97 (50.0)	2.92 (74.2)	3.56 (90.4)	0.47 (15.0)	32mm M8x1.25	0.43 (10.9)	23.62 (599.9)	0.22 (5.6)	2.36 (59.9)	1.18 (30.0)	3.13 (79.5)	0.75 (0.3)	SF-12032
40mm	4.61 (117.1)	3.78 (96.0)	2.36 (59.9)	3.77 (95.8)	4.59 (116.6)	0.59 (15.0)	40mm M10x1.50	0.55 (14.0)	27.56 (700.0)	0.32 (8.1)	2.76 (70.1)	1.48 (37.6)	3.78 (96.0)	1.45 (0.7)	SF-12040
50mm	5.35 (135.9)	4.53 (115.1)	2.36 (59.9)	4.45 (113.0)	5.26 (133.6)	0.59 (15.0)	50mm M10x1.50	0.55 (14.0)	31.50 (800.0)	0.32 (8.1)	2.76 (70.0)	1.48 (37.6)	4.53 (115.0)	1.45 (0.7)	SF-12050

*Maximum dimension in order to limit the deflection under maximum load.
*When ordering mounting plates please note they are sold per piece

Plates are mounted by means of standard screws without the need for disassembling any part of the cylinder.

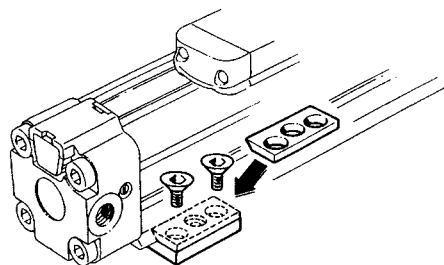
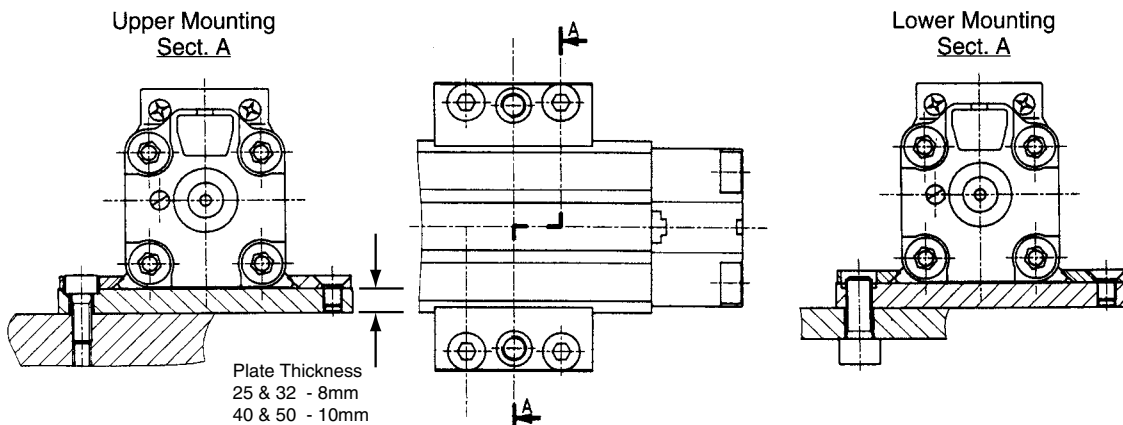

G Series - G1 & G2 Mounting Plate Location

For total bearing rail lengths of (700mm – 25/32mm bores) and (720mm – 40/50mm bores) or less, only 2 mounting plates are required. (One at each end).

For total bearing rail lengths greater than (700mm – 720mm), depending on bore diameter (see above), but less than or equal to (1300mm – 25/32mm bores) and (1320mm – 40/50mm bores), (3) mounting plates are required and the following procedures are to be used.

- a) The cylinder is oriented with the barrel on the top and the rail on the bottom, view from above (see below)

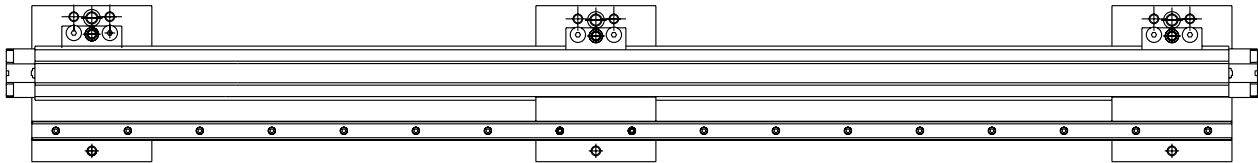

- b) Establish bearing rail hole count using supplied formula.
 c) If the hole count is even, the middle mounting plate is located at the exact half way point along the bearing rail.
 d) If the hole count is odd, locate the half way point along the bearing rail. The mounting plate is bolted to the first (2) holes to the left of center.

For total bearing rail lengths that exceed (1300mm – 25/32mm bores) and (1320mm – 40/50mm bores), (3) or more mounting plates are required and the following formulas must be used.

- a) From the center of the right end plate mounting measure 600mm to locate the center of the next mounting plate.
 b) Continue this procedure along the cylinder length until the remaining bearing rail measures greater than 600mm but less than 1200mm.
 c) Refer to (3) mounting plate procedure to locate the last mounting plate.

For strokes more than 13 ft. please consult Numatics Ltd.

NOTE: This procedure makes the assumption that there is a mounting plate at each end of the cylinder.

For 25/32 Bore Sizes

$$\text{Hole Count} = \frac{\left(\frac{\text{Stroke} + C}{60} \right) \times 60 + 60}{60}$$

25mm Medium Carriage	C = 181
25mm Long Carriage	C = 247
32mm Medium Carriage	C = 227
32mm Long Carriage	C = 322

Round down () to nearest whole number • Stroke is in millimeters

For 40/50 Bore Sizes

$$\text{Hole Count} = \frac{\left(\frac{\text{Stroke} + C}{60} \right) \times 60}{60}$$

40mm Medium Carriage	C = 272
40mm Long Carriage	C = 384
50mm Medium Carriage	C = 348
50mm Long Carriage	C = 488

Round down () to nearest whole number • Stroke is in millimeters

Extrusion Length

Extrusion Length = Stroke in Millimeters + D

	Medium Carriage	Long Carriage
25mm	D = 181.36 mm	D = 247.40 mm
32mm	D = 227.08 mm	D = 322.07 mm
40mm	D = 271.78 mm	D = 384.05 mm
50mm	D = 347.98 mm	D = 488.19 mm

G Series - G1 & G2 Mounting Instructions

The Numatics G Series guided rodless cylinder is not designed as a self-supporting beam. Mounting plates are provided every 600mm of stroke length and must be secured to a surface that will not deflect more than .010” for the given load. All mounting plates must be utilized.

Handling Precautions

- Removal of ball slide from bearing rail requires the use of NSK ball retainers.
- Bearing rail replacement requires the use of a dial indicator for bearing rail to cylinder alignment.
- Numatics G1 & G2 cylinders use NSK ‘K1’ seals as a standard on all ball slides.
 - suitable for environments where small amounts of dust or moisture is present
 - for large amounts of dust or moisture please consult factory

Lubrication

- Lubricate with NSK ‘AV2’ grease (see below)
- Frequency of lubrication is every 2,500 km or once a year.
 Note: This figure is used as a guideline only. Frequency of lubrication may vary based on cylinder application.

Removal of Carriage Plate

- Secure ball sliders before removal of carriage plate. Failure to secure ball sliders may result in the loss of ball bearings from ball sliders.
- Center cylinder (end to end) barrel on bearing rail assembly if cylinder barrel is removed for any reason. Verification of cylinder barrel to bearing rail alignment is not necessary if bearing rail is not removed.
- Removal of ‘K1’ seals on ball sliders may void warranty.

Lubrication Devices

Replenish grease to guides and ball screws by a manual type grease pump. Install the grease in bellows tube to the pump.

NSK Grease Unit

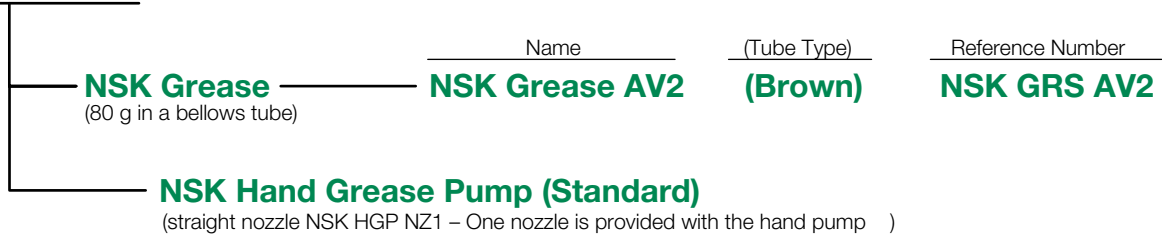

Nozzles

- NSK Flexible Nozzle – **NSK HGP NZ5** (40/50 Bore)
- NSK Fitting Nozzle – **NSK HGP NZ3** (25/32 Bore)

NR Series - S1 & S5 End Cap and Floating Mounting Brackets

End Cap Mounting Brackets for 25 & 32mm Diameter

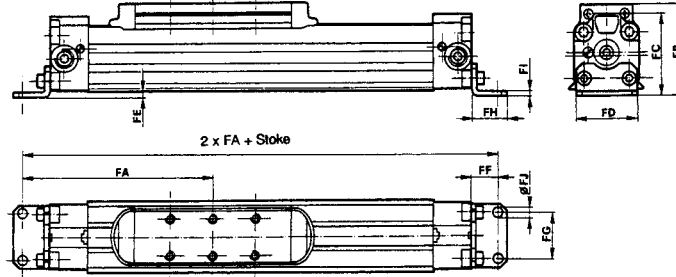

End Cap Mounting Brackets for 40 & 50mm Diameter

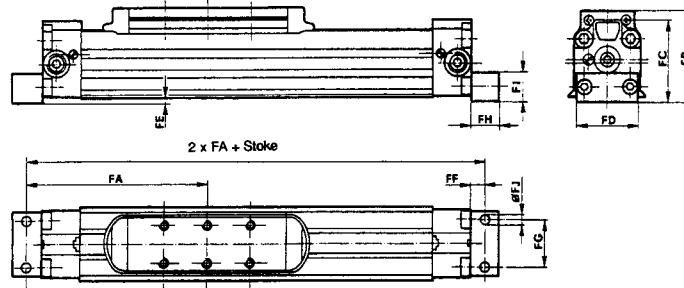

Diameter	FA	FB	FC	FD	FE	FF	FG	FH	FI	FJ	Weight lbs (kg) Stroke "0"	Ordering Code
25mm	4.57 (116.1)	2.29 (58.2)	1.92 (48.8)	1.57 (39.9)	0.02 (0.5)	0.63 (16.0)	1.06 (26.9)	0.87 (22.1)	0.10 (2.5)	0.22 (5.6)	0.07 (0.0)	SF-13025
32mm	5.65 (143.5)	2.70 (68.6)	2.33 (59.2)	1.89 (48.0)	0.10 (2.5)	0.73 (18.5)	1.42 (36.1)	1.02 (25.9)	0.12 (3.0)	0.26 (6.6)	0.12 (0.1)	SF-13032
40mm	6.40 (162.6)	3.41 (86.6)	2.95 (74.9)	2.48 (63.0)	0.03 (0.8)	0.49 (12.4)	1.18 (30.0)	0.98 (24.9)	0.98 (24.9)	0.35 (8.9)	0.26 (0.1)	SF-13040
50mm	7.46 (189.5)	4.11 (104.4)	3.64 (92.5)	3.11 (79.0)	0.05 (1.3)	0.49 (12.4)	1.57 (39.9)	0.98 (24.9)	1.18 (30.0)	0.37 (9.4)	0.37 (0.2)	SF-13050

End cap Mounting Brackets are ONLY recommended for short strokes i.e. less than 16 inches and are sold per piece

Floating Mounting Bracket

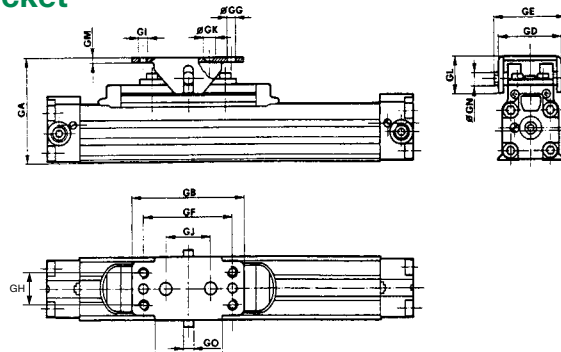

DIA.	GA	GB	GC	GD	GE	GF	GG	GH	GI	GJ	GK	GL	GM	GN	GO	Weight lbs (kg) Stroke "0"	Ordering Code
25mm	2.89 (73.4)	2.36 (59.9)	1.57 (39.9)	1.75 (44.5)	1.97 (50.0)	1.97 (50.0)	0.22 (5.6)	0.98 (24.9)	M5	0.63 (16.0)	0.22 (5.6)	0.81 (20.6)	0.12 (3.0)	0.31 (7.9)	0.24 (6.1)	0.08 (0.0)	SF-24025
32mm	3.50 (88.9)	3.94 (100.1)	2.36 (59.9)	2.20 (55.9)	2.52 (64.0)	3.15 (80.0)	0.22 (5.6)	1.18 (30.0)	M6	1.57 (39.9)	0.26 (6.6)	1.18 (30.0)	0.16 (4.1)	0.47 (11.9)	0.32 (8.1)	0.12 (0.1)	SF-24032
40mm	4.27 (108.5)	3.94 (100.1)	2.36 (59.9)	2.20 (55.9)	2.52 (64.0)	3.15 (80.0)	0.22 (5.6)	1.18 (30.0)	M6	1.57 (39.9)	0.26 (6.6)	1.18 (30.0)	0.16 (4.1)	0.47 (11.9)	0.32 (8.1)	0.26 (0.1)	SF-24032
50mm	5.27 (133.9)	6.00 (152.4)	3.86 (98.0)	2.63 (66.8)	3.00 (76.2)	4.75 (120.7)	0.26 (6.6)	1.50 (38.1)	M8	2.50 (63.5)	0.33 (8.4)	1.44 (36.6)	0.19 (4.8)	0.63 (16.0)	0.50 (12.7)	0.41 (0.2)	SF-24050

Top Dimensions = Inches • Bottom Dimensions (In Parenthesis) = Millimeters

NR Series - S5 Locking Unit

Features

- Holds Position
- Easy Mounting to either side of carriage.
- Locking force can be increased by means of an additional air signal.
- Does not increase cylinder length.

Function

The carriage unit is held firmly in place by mechanical springs. To release the locking mechanism, pressurize port "A" (Fig. 1). To increase the locking force, supply port "CH" with an air signal (Fig 2).
Note: Not a dynamic brake.

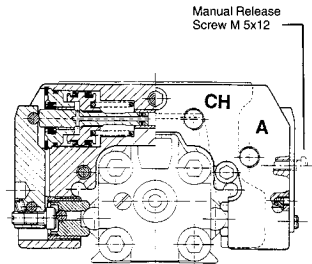

A = Release
CH = Pneumatic Lock

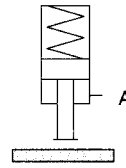

Fig. 1

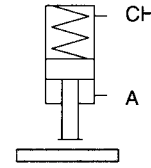

Fig. 2

Specifications

Medium: Filtered air with or without lubrication

Working Pressure: Port "A", 58 – 72 PSI
Port "CH" 30 – 72 PSI
Ambient Temperature: -22° to 175°F (-30° to 80°C)

Approximate Retaining Forces

Bore	Pressure in Lock				
	0 PSI (0 Bar)	30 PSI (2 Bar)	60 PSI (4 Bar)	80 PSI (5 Bar)	100 PSI (7 Bar)
25mm	85 lbs (380 N)	121 lbs (540 N)	152 lbs (680 N)	180 lbs (800 N)	213 lbs (950 N)
32mm	90 lbs (400 N)	153 lbs (680 N)	213 lbs (950 N)	247 lbs (1100 N)	314 lbs (1400 N)
40mm	112 lbs (500 N)	180 lbs (800 N)	236 lbs (1050 N)	270 lbs (1200 N)	326 lbs (1450 N)
50mm	152 lbs (680 N)	247 lbs (1100 N)	314 lbs (1400 N)	371 lbs (1650 N)	450 lbs (2000 N)

Working Pressure: 29-116 psi (2-8 Bar)
Minimum Release Pressure: 58-72psi (4-5 Bar)

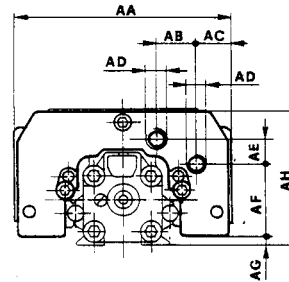
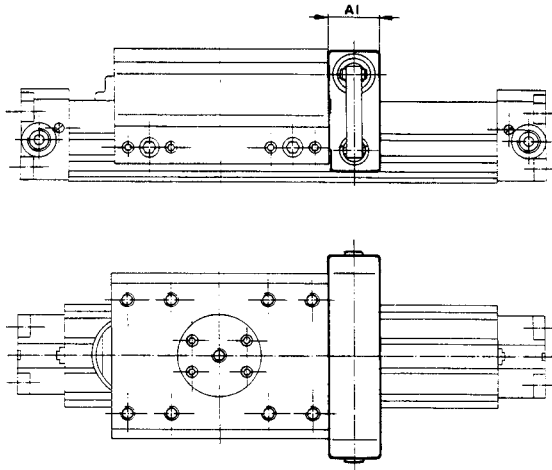

- Note:
Lock Unit Adjust
1. Connect air to unit (must be unlocked to adjust)
 2. Loosen set screws both sides
 3. Tighten adjustment screws evenly both sides to prevent binding.
 4. Should be no play between pivot arm and piston.

Dimensions: Inches (mm)

Diameter	AA	AB	AC	AD	AE	AF	AG	AH	AI	Weight lbs (kg) Stroke "0"	Weight of Locking Unit	Total Weight
25mm	4.72 (119.9)	0.96 (24.4)	0.91 (23.1)	M5	0.65 (16.5)	1.36 (34.5)	0.20 (5.1)	2.81 (71.4)	1.26 (32)	3.59 (1.6)	0.77 (0.3)	4.36 (2.0)
32mm	5.20 (132.1)	1.00 (25.4)	0.93 (23.6)	1/8"	0.68 (17.3)	1.67 (42.4)	0.26 (6.6)	3.21 (81.5)	1.26 (32)	6.24 (2.8)	1.01 (0.5)	7.25 (3.3)
40mm	5.91 (150.1)	1.02 (25.9)	1.26 (32.0)	1/8"	0.72 (18.3)	2.30 (58.4)	0.35 (8.9)	4.13 (104.9)	1.57 (39.9)	13.23 (6.0)	1.80 (0.8)	15.03 (6.8)
50mm	6.46 (164.1)	1.02 (25.9)	1.42 (36.1)	1/8"	0.78 (19.8)	2.85 (72.4)	0.50 (12.7)	4.95 (125.7)	2.01 (51.1)	21.94 (10.0)	3.20 (1.5)	25.14 (11.4)

G Series - G1 & G2 Locking Unit

This is a spring to hold and air to release locking unit. After the cylinder has achieved the desired position, exhaust the air release signal and the locking force will be applied. If a greater locking force is required an air assist supply may be applied to the unit.

Model Number Selection Chart

Bore	Model Number
25mm	MKS1501A
32mm	MKS1501A
40mm	MKS2001A
50mm	MKS2001A

Dimensions: Inches (mm)

Bore Diameter	G1 Series			G2 Series		
	H	W	E	H	W	E
25mm	3.24 (82.3)	5.12 (130.0)	0.26 (6.7)	3.24 (82.3)	5.51 (140.0)	0.77 (19.5)
32mm	3.56 (90.5)	5.12 (130.0)	0.26 (6.7)	3.56 (90.5)	5.51 (140.0)	0.77 (19.5)
40mm	4.55 (115.5)	8.46 (215.0)	0.63 (16.0)	4.55 (115.5)	8.46 (215.0)	0.63 (16.0)
50mm	5.36 (136.2)	8.46 (215.0)	0.63 (16.0)	5.36 (136.2)	8.46 (215.0)	0.63 (16.0)

Bore	Spring Force Only	Spring Plus Air Supply Force
25mm	90 lbs (400 N)	225 lbs (1000 N) @ 87 PSI (6 Bar)
32mm	90 lbs (400 N)	225 lbs (1000 N) @ 87 PSI (6 Bar)
40mm	135 lbs (600 N)	337 lbs (1500 N) @ 87 PSI (6 Bar)
50mm	135 lbs (600 N)	337 lbs (1500 N) @ 87 PSI (6 Bar)

Plus Connection: by use of a 5/3 valve plus connection is made by removing M5 filter and replacing with second connection

Air Requirements: Clean lubricated air supply opening pressure 80PSI (5.5) Bar. Max pressure 87PSI (6) Bar

Note: To connect the air signal for additional holding force remove the factory installed vent/filter plug and replace with a holding pressure supply. The holding pressure supply should be present only when the unit is in the desired position and the release signal is exhausted.

Locking units are a static device not dynamic. Locking units are not a load unit with use of locking unit long carriage cylinders will have medium carriage loads

Installation

Locking units are factory installed and utilize the G1 or G2 Series long carriage. The locking unit is installed in place of the middle bearing slider.

Ordering Information

Select the appropriate bore size in the G1 or G2 Series Rodless cylinder with a long carriage and insert one of the following suffixes in the 13th and 14th "Options" spaces.

OL Locking Unit only

ML Locking unit and Switch Magnets



Note: For single rail 40 & 50 series bores, top and bottom plates are same as G2

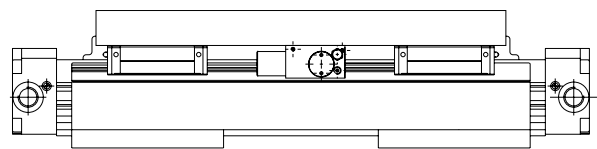
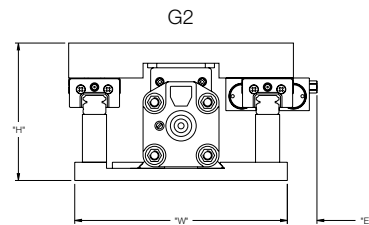
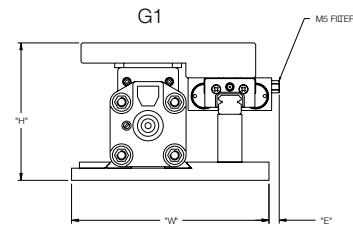

NR & G Series - Single End Supply, End of Stroke Shock Kit

For S1, S5, G1 and G2 Series

Installation

Each kit includes mounting screws that secure the shock brackets to the recessed thread on the end cap bolts. Thread the shock into the bracket and adjust the position accordingly. On the S5 Series the piston strikes a hardened insert (included with all kits) that is threaded into a hole located on the center of the external carriage. When utilizing a shock kit on the S1 Series provisions must be made to the tooling mounted on the carriage to strike the shock piston rod.

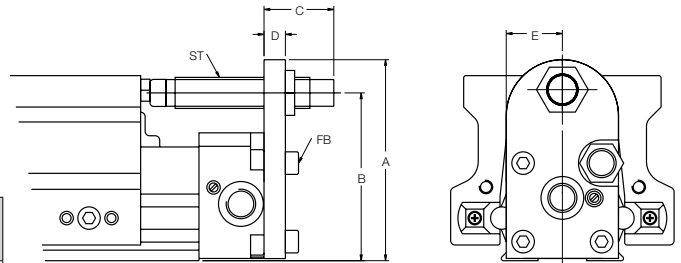

These end of stroke shock kits are used for single end supply and can be utilized in applications when the mass and speed exceeds the internal cushion capacity of the cylinder.

Model Number Selection Chart

Bore	Mounting Kit Only	Kit with Standard Duty Shock	Kit with Medium Duty Shock	Kit with Heavy Duty Shock
25mm	NR014025	NR114025	NR214025	NR314025
32mm	NR014032	NR114032	NR214032	NR314032
40mm	NR014040	NR114040	NR214040	NR314040
50mm	NR014050	NR114050	NR214050	NR314050

Dimensions and Shock Data

Diameter	A	B	C	D	E	FB	ST	Shock Series	OAL	Stroke	Thread Length	Nut Width
25mm	3.13 (79.5)	2.63 (66.8)	1.55 (39.4)	0.37 (9.4)	0.80 (20.3)	M5x8	M14x1.5	NC-S0.25-__L	3.58 (91)	0.551 (14)	2.40 (61.0)	0.20 (5.1)
32mm	3.53 (89.7)	2.95 (74.9)	1.23 (31.2)	0.37 (9.4)	1.00 (25.4)	M6x1	M14x1.5	NC-S0.25-__L	3.58 (91)	0.551 (14)	2.40 (61.0)	0.20 (5.1)
40mm	4.56 (115.8)	3.92 (99.6)	0.76 (19.3)	0.37 (9.4)	1.26 (32.0)	M8x1.25	M20x1.5	NC-S0.5x19__L	4.21 (107)	0.748 (19)	2.43 (61.7)	0.24 (6.1)
50mm	5.38 (136.7)	4.64 (117.9)	2.38 (60.5)	0.37 (9.4)	1.57 (39.9)	M10x1.5	M20x1.5	NC-S1.0__T	5.24 (133)	0.984 (25)	4.22 (107.2)	0.32 (8.1)

NR Series - End of Stroke Shock Kits

For S1, and S5 Series

End of Stroke Shock Kits can be utilized in applications when the mass and speed exceeds the internal cushion capacity of the cylinder.

Installation

Each kit includes two mounting screws that secure the shock brackets to the recessed thread on the end cap bolts. Thread the shock into the bracket and adjust the position accordingly. On the S5 Series the piston strikes a hardened insert (included with all kits) that is threaded into a hole located on the center of the external carriage. When utilizing a shock kit on the S1 Series provisions must be made to the tooling mounted on the carriage to strike the shock piston rod.

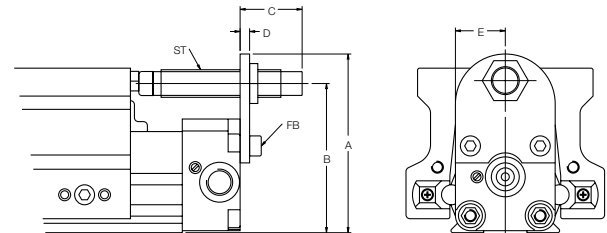

Model Number Selection Chart

Bore	Mounting Kit Only	Kit with Standard Duty Shock	Kit with Medium Duty Shock	Kit with Heavy Duty Shock
25mm	NR013025	NR113025	NR213025	NR313025
32mm	NR013032	NR113032	NR213032	NR313032
40mm	NR013040	NR113040	NR213040	NR313040
50mm	NR013050	NR113050	NR213050	NR313050

Dimensions and Shock Data

Bore	A	B	C	D	E	FB	ST	Shock Series	OAL	Stroke	Thread Length	Nut Width	Soft Pad
25mm	3.13 (79.5)	2.63 (66.8)	1.55 (39.4)	0.19 (4.8)	0.80 (20.3)	M5x8	M14x1.5	150	3.43 (87.1)	0.47 (11.9)	2.40 (61.0)	0.20 (5.1)	0.27 (6.9)
32mm	3.53 (89.7)	2.95 (74.9)	1.23 (31.2)	0.19 (4.8)	0.98 (24.9)	M6x1	M14x1.5	150	3.43 (87.1)	0.47 (11.9)	2.40 (61.0)	0.20 (5.1)	0.27 (6.9)
40mm	4.56 (115.8)	3.92 (99.6)	0.76 (19.3)	0.25 (6.4)	1.26 (32.0)	M8x1.25	M20x1.5	225	3.50 (88.9)	0.47 (11.9)	2.43 (61.7)	0.24 (6.1)	0.19 (4.8)
50mm	5.38 (136.7)	4.64 (117.9)	2.38 (60.5)	0.25 (6.4)	1.57 (39.9)	M10x1.5	M20x1.5	600	5.87 (149.1)	0.97 (24.6)	4.22 (107.2)	0.32 (8.1)	0.25 (6.4)

Top Dimensions = Inches • Bottom Dimensions (In Parenthesis) = Millimeters

NR Series - Stroke Adjustments Kits

For S1 and S5 Series

A stroke adjustment kit for the S1 and S5 Series will allow field adjustment of stroke length.

Installation

The stroke adjustment kit includes a shock, shock bracket, base plate, four mounting brackets and all necessary fasteners. First place the base plate under the rodless barrel extrusion. Next mount the shock bracket to the base plate utilizing the appropriate screws. Now position the assembly to achieve the desired stroke and secure it to the foot-mounting flange by tightening the four mounting brackets. Finally install the hardened insert into the threaded hole located in the center of the S5 external carriages. When utilizing the stroke adjustment kit on the S1 Series provisions must be made to the tooling mounted on the carriage to strike the shock piston rod.

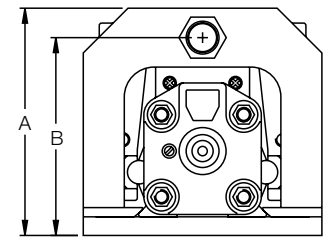
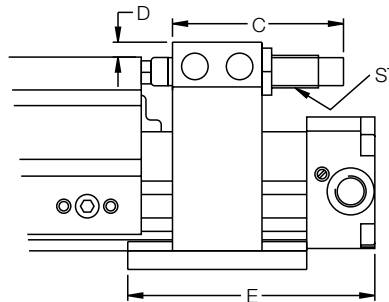
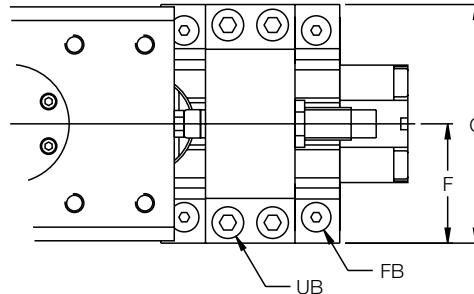

Model Number Selection

Bore	Mounting Kit Only	Kit with Standard Duty Shock	Kit with Medium Duty Shock	Kit with Heavy Duty Shock
25mm	NR012025	NR112025	NR212025	NR312025
32mm	NR012032	NR112032	NR212032	NR312032
40mm	NR012040	NR112040	NR212040	NR312040
50mm	NR012050	NR112050	NR212050	NR312050

Dimensions: Inches (mm)

Shock Data and Dimensions

Bore	A	B	C	"S5" D	"S1" D	E	F	G	FB	UB	ST	Shock Series	OAL	Stroke	Thread Length	Nut Width
25mm	3.47 (88.1)	3.94 (100.1)	2.74 (69.6)	0.33 (8.4)	0.23 (5.8)	3.95 (100.3)	1.75 (44.5)	3.50 (88.9)	M8x60	M6x12	M14x1.5	NC-S0.25-__L	3.58 (91)	0.551 (14)	2.40 (61.0)	0.20 (5.1)
32mm	3.81 (96.8)	4.14 (105.2)	2.87 (72.9)	0.25 (6.4)	0.25 (6.4)	4.14 (105.2)	2.00 (50.8)	4.00 (101.6)	M8x70	M6x12	M14x1.5	NC-S0.25-__L	3.58 (91)	0.551 (14)	2.40 (61.0)	0.20 (5.1)
40mm	4.88 (124.0)	4.30 (109.2)	2.81 (71.4)	0.33 (8.4)	0.35 (8.9)	4.30 (109.2)	2.63 (66.8)	5.25 (133.4)	M10x90	M8x14	M20x1.5	NC-S0.5x19__L	4.21 (107)	0.748 (19)	2.43 (61.7)	0.24 (6.1)
50mm	5.52 (140.2)	4.30 (109.2)	4.92 (125.0)	0.30 (7.6)	0.17 (4.3)	4.30 (109.2)	3.00 (76.2)	6.00 (152.4)	M10x100	M8x14	M20x1.5	NC-S1.0__T	5.24 (133)	0.984 (25)	4.22 (107.2)	0.32 (8.1)

Adder Chart

Bore	Adder
25mm	2.00 (50.8)
32mm	1.75 (44.5)
40mm	1.50 (38.1)
50mm	1.00 (25.4)

Note: These dimensions must be added to the desired stroke length in order to allow for the bracket placement on the cylinder. (For example, if ordering a 25mm, 12" stroke cylinder with a mounting bracket, a 2.00" adder would be required making the overall length 14")

The Stroke Adjustment Kit must always be used with a properly functioning shock absorber.

**G Series - Adjustable Stroke Kit
For S1 and S5 Series**

G Series stroke adjustment kits will enable field adjustment of stroke length.

Installation

Each kit includes a two piece assembly that mounts onto the bearing rail. To install, loosen the position locking screw and slide onto the bearing rail. Once it is in the position to achieve the desired stroke length, tighten the locking screw.

Note: The stroke adjustment kit must always incorporate a shock absorber. It is necessary to add 1 inch to the stroke of the cylinder for each stroke adjustment kit.

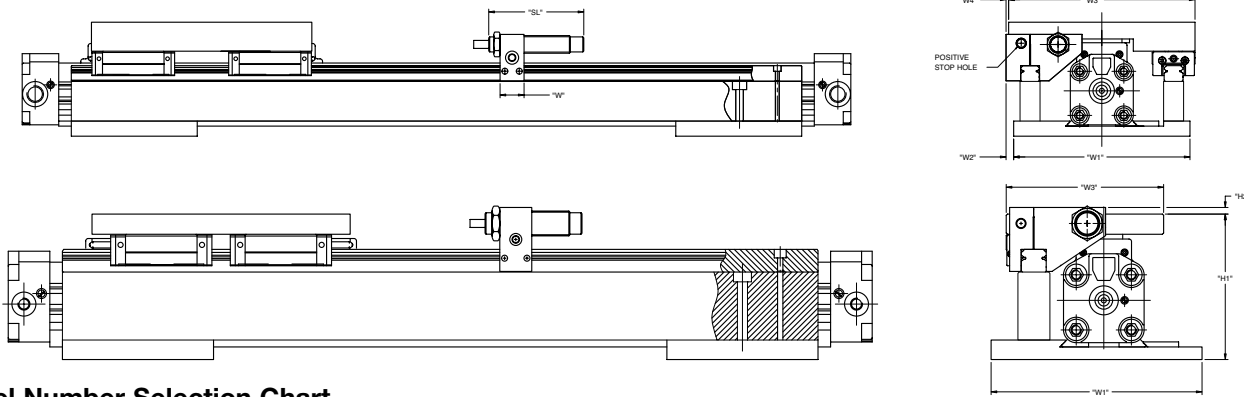
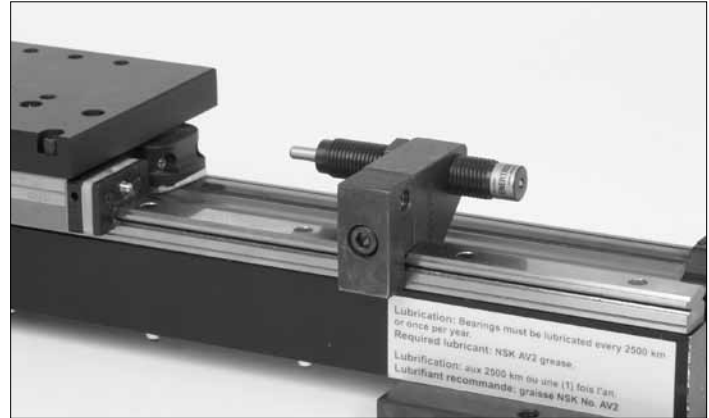

Model Number Selection Chart

Bore	Mounting Kit Only	Kit with Standard Duty Shock	Kit with Medium Duty Shock	Kit with Heavy Duty Shock
25mm	NR015025	NR115025	NR215025	NR315025
32mm	NR015032	NR115032	NR215032	NR315032
40mm	NR015040	NR115040	NR215040	NR315040
50mm	NR015050	NR115050	NR215050	NR315050

G1 Series - Shock Chart and Dimensions

top dimensions = inches and bottom dimensions (in parenthesis) = millimeters

Bore Diameter	W	W1	W2	W3	W4	H1	H2	Shock Series	Shock Hole Thread Size	Positive Stop Hole Thread Size	SL
25mm	0.75 (19.1)	5.12 (130.0)	-	3.94 (100.1)	0.08 (2.0)	3.24 (82.3)	-	NC-S0.25__L	M14 x 1.5	M8 x 1.25	3.031 (77)
32mm	0.75 (19.1)	5.12 (130.0)	-	4.53 (115.1)	0.08 (2.0)	3.54 (89.9)	-	NC-S0.25__L	M14 x 1.5	M8 x 1.25	3.031 (77)
40mm	1.00 (25.4)	6.59 (167.4)	-	4.92 (125.0)	-	4.55 (115.6)	0.21 (5.3)	NC-S0.5x19__L	M20 x 1.5	M8 x 1.25	3.465 (88)
50mm	1.00 (25.4)	6.59 (167.4)	-	4.92 (125.0)	-	5.36 (136.1)	-	NC-S1.0__T	M20 x 1.5	M8 x 1.25	4.250 (108)

G2 Series - Shock Chart and Dimensions

top dimensions = inches and bottom dimensions (in parenthesis) = millimeters

Bore Diameter	W	W1	W2	W3	W4	H1	H2	Shock Series	Shock Hole Thread Size	Positive Stop Hole Thread Size	SL
25mm	0.75 (19.1)	5.51 (140.0)	0.24 (6.1)	5.83 (148.0)	-	3.24 (82.3)	-	NC-S0.25__L	M14 x 1.5	M8 x 1.25	3.031 (77)
32mm	0.75 (19.1)	5.51 (140.0)	0.24 (6.1)	5.83 (148.0)	0.08 (2.0)	3.54 (89.9)	-	NC-S0.25__L	M14 x 1.5	M8 x 1.25	3.031 (77)
40mm	1.00 (25.4)	8.46 (215.0)	-	8.46 (215.0)	0.11 (2.7)	4.55 (115.6)	0.21 (5.3)	NC-S0.5x19__L	M20 x 1.5	M8 x 1.25	3.465 (88)
50mm	1.00 (25.4)	8.46 (215.0)	-	8.46 (215.0)	-	5.36 (136.1)	-	NC-S1.0__T	M20 x 1.5	M8 x 1.25	4.250 (108)

NR & G Series - End of Stroke Shock Brackets

Bracket Only (includes bracket and two mounting screws)

Bore	Kit Part Number	Bracket	Mounting Bolts	Striker Bolts
25mm	NR013025	98017SPEC	M5x16SPEC (2)	M6x10SPEC
32mm	NR013032	98017SPEC	M6x20SPEC (2)	M6x10SPEC
40mm	NR013040	98017SPEC	M8x25SPEC (2)	M6x10SPEC
50mm	NR013050	98017SPEC	M10x25SPEC (2)	M8x16SPEC

S1, S5, G1 & G2 Series
Non-Single, End Supply

Note: Customer must supply their own
"Striking Bar" for the S1 Series Rodless
cylinders.

Bracket and Light Duty Shock

Bore	Kit Part Number	Bracket	Mounting Bolts	Striker Bolts	Soft Pad
25mm	NR113025	98017SPEC	M5x16SPEC (2)	M6x10SPEC	3115-19015
32mm	NR113032	98017SPEC	M6x20SPEC (2)	M6x10SPEC	3115-19015
40mm	NR113040	98017SPEC	M8x25SPEC (2)	M6x10SPEC	3115-19015
50mm	NR113050	98017SPEC	M10x25SPEC (2)	M8x16SPEC	3115-19015

Bracket and Medium Duty Shock

Bore	Kit Part Number	Bracket	Mounting Bolts	Striker Bolts	Soft Pad
25mm	NR213025	98017SPEC	M5x16SPEC (2)	M6x10SPEC	3115-19015
32mm	NR213032	98017SPEC	M6x20SPEC (2)	M6x10SPEC	3115-19015
40mm	NR213040	98017SPEC	M8x25SPEC (2)	M6x10SPEC	3115-19015
50mm	NR213050	98017SPEC	M10x25SPEC (2)	M8x16SPEC	3115-19015

Bracket and Heavy Duty Shock

Bore	Kit Part Number	Bracket	Mounting Bolts	Striker Bolts	Soft Pad
25mm	NR313025	98017SPEC	M5x16SPEC (2)	M6x10SPEC	3115-19015
32mm	NR313032	98017SPEC	M6x20SPEC (2)	M6x10SPEC	3115-19015
40mm	NR313040	98017SPEC	M8x25SPEC (2)	M6x10SPEC	3115-19015
50mm	NR313050	98017SPEC	M10x25SPEC (2)	M8x16SPEC	3115-19015

NR Series - S1 & S5 Adjustable Stroke Brackets

Bracket Only (includes bracket, mounting plates and screws)

Bore	Kit Part Number	Bracket Kit	Striker Bolts	Shock Threads
25mm	NR012025	98049SPEC	M6x10SPEC	M14x1.5
32mm	NR012032	98050SPEC	M6x10SPEC	M14x1.5
40mm	NR012040	98051SPEC	M6x10SPEC	M20x1.5
50mm	NR012050	98052SPEC	M8x16SPEC	M25x1.5

S1 and S5 Series Only

Bracket and Light Duty Shock

Bore	Kit Part Number	Bracket Kit	Striker Bolts	Soft Pad
25mm	NR112025	98049SPEC	M6x10SPEC	3115-19015
32mm	NR112032	98050SPEC	M6x10SPEC	3115-19015
40mm	NR112040	98051SPEC	M6x10SPEC	3115-19015
50mm	NR112050	98052SPEC	M8x16SPEC	3115-19015

Bracket and Medium Duty Shock

Bore	Kit Part Number	Bracket Kit	Striker Bolts	Soft Pad
25mm	NR212025	98049SPEC	M6x10SPEC	3115-19015
32mm	NR212032	98050SPEC	M6x10SPEC	3115-19015
40mm	NR212040	98051SPEC	M6x10SPEC	3115-19015
50mm	NR212050	98052SPEC	M8x16SPEC	3115-19015

Bracket and Heavy Duty Shock

Bore	Kit Part Number	Bracket Kit	Striker Bolts	Soft Pad
25mm	NR312025	98049SPEC	M6x10SPEC	3115-19015
32mm	NR312032	98050SPEC	M6x10SPEC	3115-19015
40mm	NR312040	98051SPEC	M6x10SPEC	3115-19015
50mm	NR312050	98052SPEC	M8x16SPEC	3115-19015

Switch Mounting Kits

For S5 Series

The Switch mounting system for the S5 Series rodless cylinders will consist of switch mounting brackets and magnet holders. The Switch Mounting brackets attach to the extruded foot along the bottom side of the barrel while the magnet holder is attached to a tapped hole located on the underside of the externally guided carriage.

Model Number Selection Chart

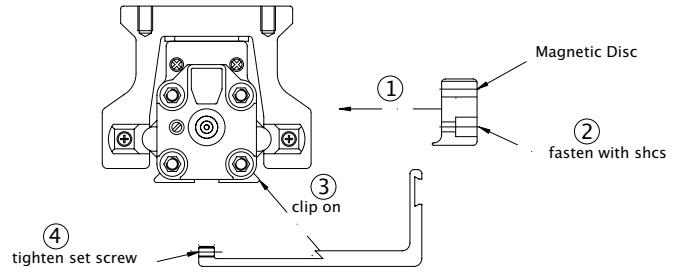
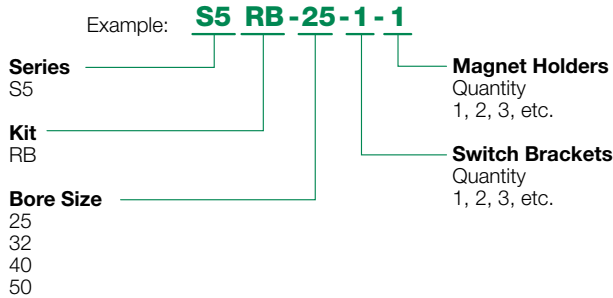

For S1 Series

All S1 and G series rodless cylinders use the same mounting bracket kit. The part number is: US1RB

1. Insert bracket pieces (1) and (2) into cylinder extrusion. Tighten set screw to lock pieces together. Insert switch into slot.
2. Insert switch into slot. Tighten Phillips head screw to lock switch into place.

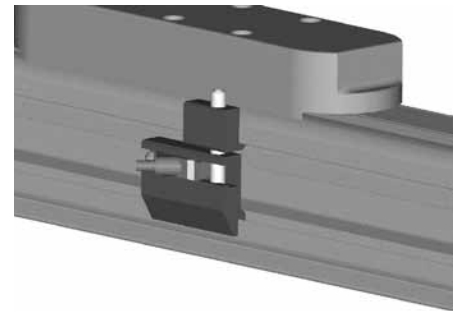
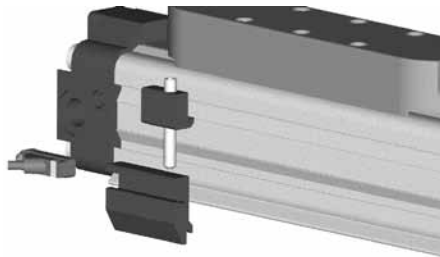

Switch Wire Cover

For S1 Series

Numatics has available a wire cover system for the S1 Series Rodless Cylinder. It provides both support and concealment of the switch wires along the side of the cylinder.

Installation

The cover is made from flexible plastic. By slightly bending the cover it is fitted into the switch groove that runs along either side of the S1 Series barrel extrusion.

How To Order

The wire cover is sold by the inch. To order, determine the length required in inches and use that number as the quantity for the appropriate size cover.

Model Number Selection

Bore	Model Number
25mm	NR004032
32mm	NR004032
40mm	NR004040
50mm	NR004050

~.50 FOR ALL BORE SIZES

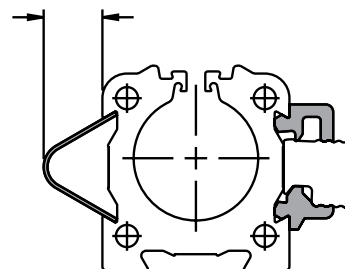

Rodless Cylinders Switch Mounting Kits

For S5 Series

The Switch mounting system for the S5 Series rodless cylinders will consist of switch mounting brackets and magnet holders. The Switch Mounting brackets attach to the extruded foot along the bottom side of the barrel while the magnet holder is attached to a tapped hole located on the underside of the externally guided carriage.

Model Number Selection Chart

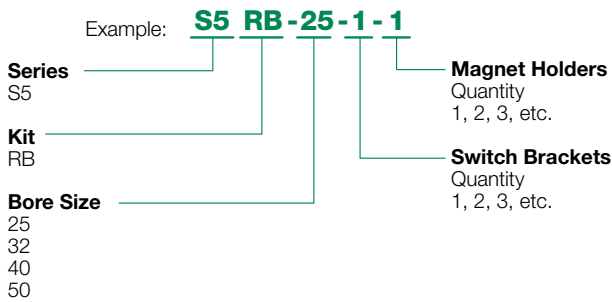

Sensor Description	Standard Cord Set	Quick Disconnect
Reed Switch	REED-FL2-00	REED-QDS-M8U
Hall PNP	PNP-FL2-00-U	PNP-QDS-M8-U
Hall NPN	NPN-FL2-00-U	NPN-QDS-M8-U

See page 26, 27, & 28 for sensor specifications

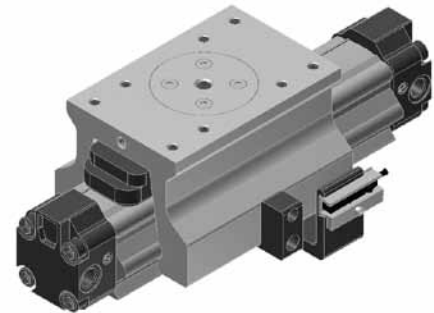

Rodless Cylinder (G Series)

Bore	Bracket P/N
25mm	US1RB
32mm	US1RB
40mm	US1RB
50mm	US1RB



Sensor Description	Standard Cord Set	Quick Disconnect
Reed Switch	REED-FL2-00	REED-QDS-M8U
Hall PNP	PNP-FL2-00-U	PNP-QDS-M8-U
Hall NPN	NPN-FL2-00-U	NPN-QDS-M8-U

See page 26, 27, & 28 for sensor specifications

Sensing Part Numbers

PNP-FL2-00-U

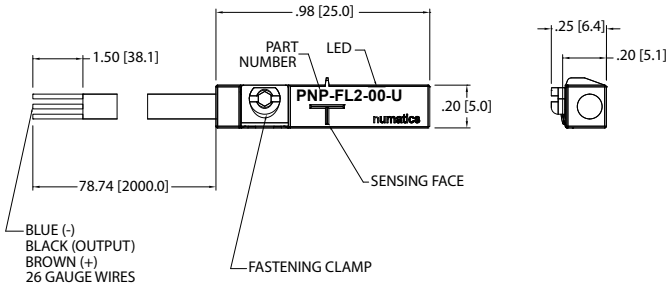

PNP-QDS-M8-U

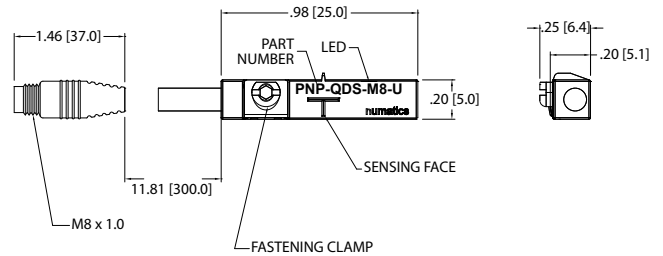





ELECTRICAL DESIGN	DC PNP
OUTPUT	Normally Open
OPERATING VOLTAGE	10-30 VDC
CURRENT RATING	100 mA
SHORT-CIRCUIT PROTECTION	Yes
OVERLOAD PROTECTION	Yes
REVERSE POLARITY PROTECTION	Yes
VOLTAGE DROP	< 2.5 V
CURRENT CONSUMPTION	< 12 mA
REPEATABILITY	< .2mm
POWER-ON DELAY TIME	< 30 ms
SWITCH FREQUENCY	> 3000 Hz
AMBIENT TEMPERATURE	-25°C to 85°C
PROTECTION	IP 67, III
HYSTERESIS	1.0mm
MAGNETIC SENSITIVITY	2.0 mT
TRAVEL SPEED	> 10 m/s
HOUSING MATERIAL	PA (Polyamide) Black; Fastening Clamp: Stainless Steel
FUNCTION DISPLAY SWITCHING STATUS	Yellow LED
CONNECTION	Flying Leads, Pur Cable (2m Long, 3 x26 Gauge Wire)
REMARKS	Clamping Screw with Combined Slot/Hexagon Socket Head AF 1.5 cULus - Class 2 Source Required
ACCESSORIES	Rubber Placeholder, Cable Clip, and Cut Sheet To Be Provided with Every Switch
AGENCY APPROVALS	

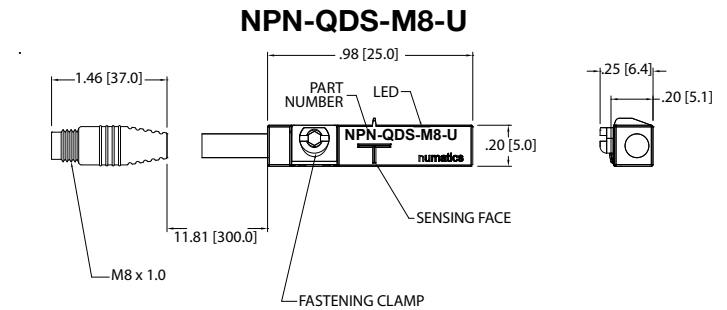
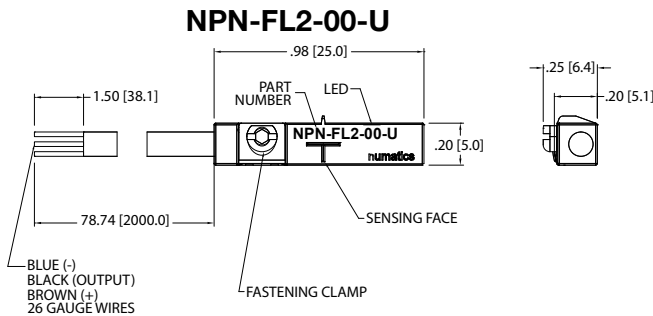

ELECTRICAL DESIGN	DC PNP
OUTPUT	Normally Open
OPERATING VOLTAGE	10-30 VDC
CURRENT RATING	100 mA
SHORT-CIRCUIT PROTECTION	Yes
OVERLOAD PROTECTION	Yes
REVERSE POLARITY PROTECTION	Yes
VOLTAGE DROP	< 2.5 V
CURRENT CONSUMPTION	< 12 mA
REPEATABILITY	< .2mm
POWER-ON DELAY TIME	< 30 ms
SWITCH FREQUENCY	> 3000 Hz
AMBIENT TEMPERATURE	-25°C to 85°C
PROTECTION	IP 67, III
HYSTERESIS	1.0mm
MAGNETIC SENSITIVITY	2.0 mT
TRAVEL SPEED	> 10 m/s
HOUSING MATERIAL	PA (Polyamide) Black; Fastening Clamp: Stainless Steel
FUNCTION DISPLAY SWITCHING STATUS	Yellow LED
CONNECTION	M8 Connector (Snap Fit) , Pur Cable (.3 m)
REMARKS	Clamping Screw with Combined Slot/Hexagon Socket Head AF 1.5 cULus - Class 2 Source Required
ACCESSORIES	Rubber Placeholder, Cable Clip, and Cut Sheet To Be Provided with Every Switch
AGENCY APPROVALS	

*Switches are not designed for wet environments. Please see your distributor for additional information.

Sensing Part Numbers



ELECTRICAL DESIGN	DC NPN
OUTPUT	Normally Open
OPERATING VOLTAGE	10-30 VDC
CURRENT RATING	100 mA
SHORT-CIRCUIT PROTECTION	Yes
OVERLOAD PROTECTION	Yes
REVERSE POLARITY PROTECTION	Yes
VOLTAGE DROP	< 2.5 V
CURRENT CONSUMPTION	< 12 mA
REPEATABILITY	< .2mm
POWER-ON DELAY TIME	< 30 ms
SWITCH FREQUENCY	> 3000 Hz
AMBIENT TEMPERATURE	-25°C to 85°C
PROTECTION	IP 67, III
HYSTERESIS	1.0mm
MAGNETIC SENSITIVITY	2.0 mT
TRAVEL SPEED	> 10 m/s
HOUSING MATERIAL	PA (Polyamide) Black; Fastening Clamp: Stainless Steel
FUNCTION DISPLAY SWITCHING STATUS	Yellow LED
CONNECTION	Flying Leads, Pur Cable (2m Long, 3 x26 Gauge Wire)
REMARKS	Clamping Screw with Combined Slot/Hexagon Socket Head AF 1.5 cULus - Class 2 Source Required
ACCESSORIES	Rubber Placeholder, Cable Clip, and Cut Sheet To Be Provided with Every Switch
AGENCY APPROVALS	  

ELECTRICAL DESIGN	DC NPN
OUTPUT	Normally Open
OPERATING VOLTAGE	10-30 VDC
CURRENT RATING	100 mA
SHORT-CIRCUIT PROTECTION	Yes
OVERLOAD PROTECTION	Yes
REVERSE POLARITY PROTECTION	Yes
VOLTAGE DROP	< 2.5 V
CURRENT CONSUMPTION	< 12 mA
REPEATABILITY	< .2mm
POWER-ON DELAY TIME	< 30 ms
SWITCH FREQUENCY	> 3000 Hz
AMBIENT TEMPERATURE	-25°C to 85°C
PROTECTION	IP 67, III
HYSTERESIS	1.0mm
MAGNETIC SENSITIVITY	2.0 mT
TRAVEL SPEED	> 10 m/s
HOUSING MATERIAL	PA (Polyamide) Black; Fastening Clamp: Stainless Steel
FUNCTION DISPLAY SWITCHING STATUS	Yellow LED
CONNECTION	M8 Connector (Snap Fit) , Pur Cable (.3 m)
REMARKS	Clamping Screw with Combined Slot/Hexagon Socket Head AF 1.5 cULus - Class 2 Source Required
ACCESSORIES	Rubber Placeholder, Cable Clip, and Cut Sheet To Be Provided with Every Switch
AGENCY APPROVALS	  

*Switches are not designed for wet environments. Please see your distributor for additional information.

Sensing Part Numbers

REED-FL2-00

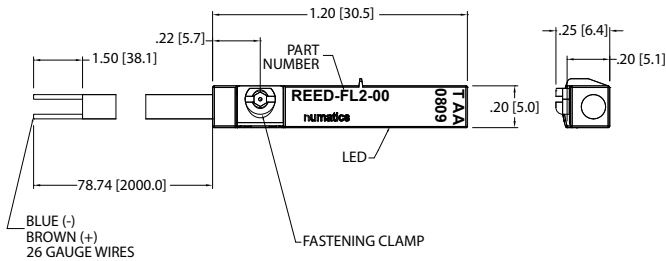

REED-QDS-M8U

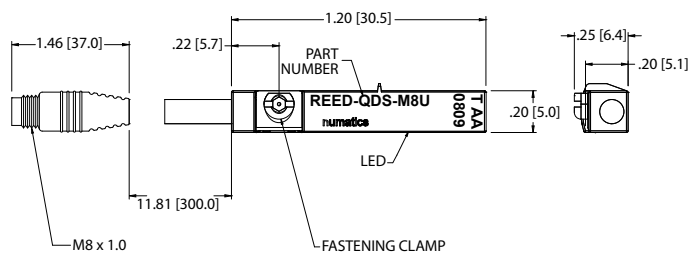

ELECTRICAL DESIGN	AC/DC REED
OUTPUT	Normally Open
OPERATING VOLTAGE	5-120 VAC/DC
CURRENT RATING	100 mA*
SHORT-CIRCUIT PROTECTION	No
OVERLOAD PROTECTION	No
REVERSE POLARITY PROTECTION	Yes
VOLTAGE DROP	< 5 V
REPEATABILITY	± .2mm
MAKETIME INCLUDING BOUNCE	< .6 ms
BREAKTIME	< .1 ms
SWITCHING POWER (MAX)	5 W
SWITCH FREQUENCY	1000 Hz
AMBIENT TEMPERATURE	-25°C to 70°C
PROTECTION	IP 67, II
HYSTERESIS	.9mm
HOUSING MATERIAL	PA (Polyamide) Black; Fastening Clamp: Stainless Steel
FUNCTION DISPLAY SWITCHING STATUS	Yellow LED
CONNECTION	Flying Leads, Pur Cable (2m Long, 2 x26 Gauge Wire)
REMARKS	*External Protective Circuit for Inductive Load (Valve, Contactor, Etc..) Necessary. Conforms to 2008 NEC Section 725 III, Class 2 Circuits Clamping Screw with Combined Slot/Hexagon Socket Head AF 1.5. No LED Function in case of Polarity in DC Operation
ACCESSORIES	Rubber Placehold, Cable Clip, and Cut Sheet To Be Provided with Every Switch
AGENCY APPROVALS	

ELECTRICAL DESIGN	AC/DC REED
OUTPUT	Normally Open
OPERATING VOLTAGE	*5-60 VDC / 5-50 VAC
CURRENT RATING	100 mA
SHORT-CIRCUIT PROTECTION	No
OVERLOAD PROTECTION	No
REVERSE POLARITY PROTECTION	Yes
VOLTAGE DROP	< 5 V
REPEATABILITY	± .2mm
MAKETIME INCLUDING BOUNCE	< .6 ms
BREAKTIME	< .1 ms
SWITCHING POWER (MAX)	5 W
SWITCH FREQUENCY	1000 Hz
AMBIENT TEMPERATURE	-25°C to 70°C
PROTECTION	IP 67, II
HYSTERESIS	.9mm
HOUSING MATERIAL	PA (Polyamide) Black; Fastening Clamp: Stainless Steel
FUNCTION DISPLAY SWITCHING STATUS	Yellow LED
CONNECTION	M8 Connector (Snap Fit), Pur Cable (.3m)
REMARKS	*External Protective Circuit for Inductive Load (Valve, Contactor, Etc..) Necessary. Conforms to 2008 NEC Section 725 III, Class 2 Circuits M8 Connector voltage limited to 5-60 vdc / 5-50 vac to conform with 2008 IEC 61076-2-104 Clamping Screw with Combined Slot/Hexagon Socket Head AF 1.5. No LED Function in case of Polarity in DC Operation
ACCESSORIES	Rubber Placehold, Cable Clip, and Cut Sheet To Be Provided with Every Switch
AGENCY APPROVALS	

*Switches are not designed for wet environments. Please see your distributor for additional information.

Quick Disconnect Cables

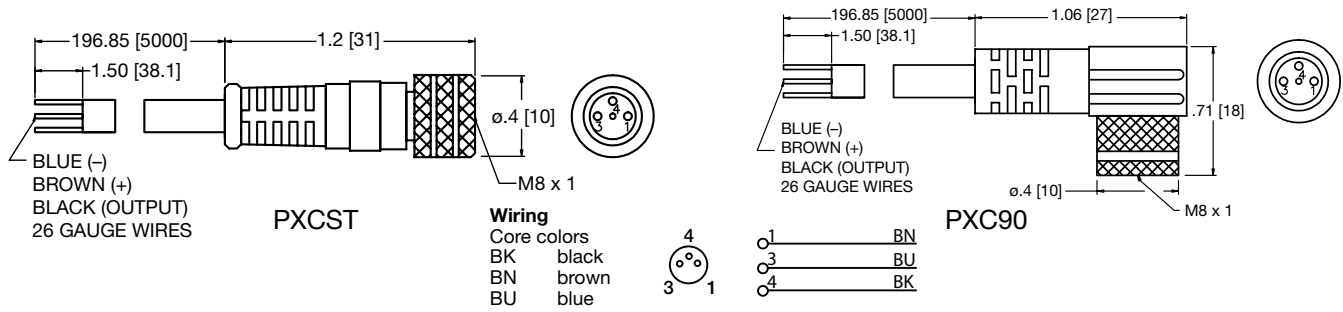

Order Code	Type	Operating Voltage	Current Rating	Cable Material	Protection	Connector
PXCST	Straight 5 m Cable (3 x 26 Gauge wire)	60 AC/75 DC	3 A	PUR	IP 68, III	M8
PXC90	90° 5 m Cable (3 x 26 Gauge wire)	60 AC/75 DC	3 A	PUR	IP 68, III	M8

NR & G Series - Service Kits & Accessories

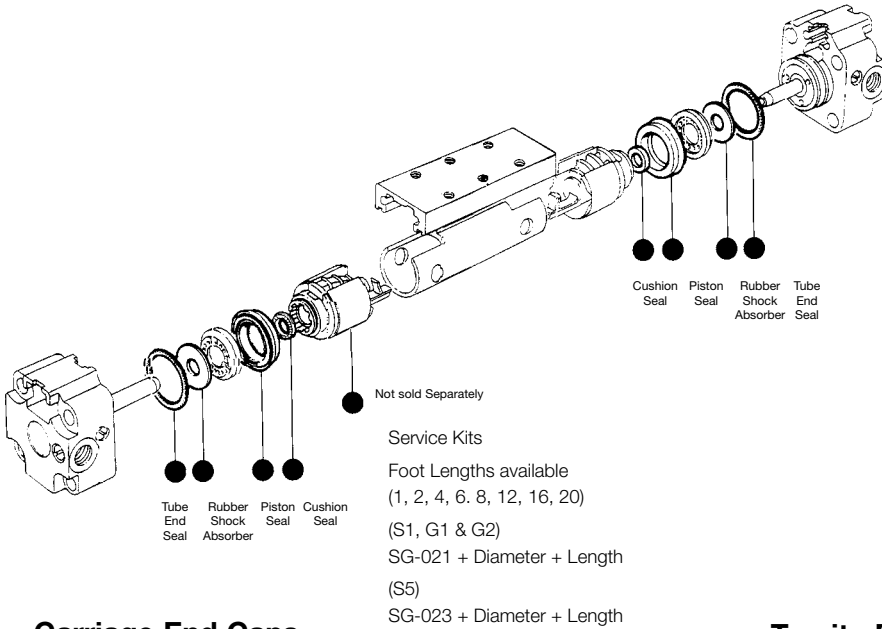

Service Kits
Foot Lengths available
(1, 2, 4, 6, 8, 12, 16, 20)
(S1, G1 & G2)
SG-021 + Diameter + Length
(S5)
SG-023 + Diameter + Length

Strip Seal Kit:

All Dia. supplied in 23 ft. (7m) lengths

Internal

Ordering code
25-32 diameter. SK180320007
40-50 diameter. SK180500007

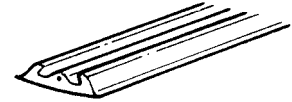

External

Ordering code
25-50 diameter. SK190500007

Carriage End Caps

Ordering code
SR - 185 + Diameter

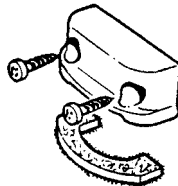

Turcite Bearing (S5)

Ordering code
25 diameter. SR170025
32 diameter. SR170032
40-50 diameter. SR170050

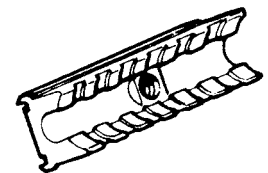

Locking plugs

Ordering code
Inside **SR182050**
Outside **SR1830 +Diameter**



End Caps & Felts for External Guides (S5 Series) Wiper Seals

Ordering code
25-32 diameter. **SR172032**
40-50 diameter. **SR172050**



Wear Pads (Piston Guide)

Ordering code
25-32 Bore **8L4-7227**
40-50 Bore **8L4-7228**



Magnet Parts

Ordering code
SK1610 + Diameter



Bearing Block

Ordering code
25-32 dia. **EGH-15-CA-Z0-H**
40-50 dia. **LAH20AN-K**

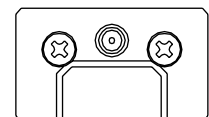

Bearing Rail

Ordering code
25-32 dia. **L1S15XXXX-Z**
40-50 dia. **L1H20XXXX-Z**
(XXXX = length in millimeters)

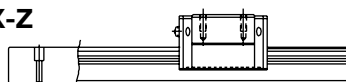

Bearing Rail Cap

Ordering code
25-32 dia. **L45800003-003**
40-50 dia. **L45800005-003**



NUMATICS®

World Class Supplier of Pneumatic Components



World Headquarters

USA Numatics, Incorporated

46280 Dylan Drive
Novi, Michigan 48377

P: 248-596-3200
F: 248-596-3201

Canada Numatics, Ltd

P: 519-758-2700
F: 519-758-5540

México - Ascomatica SA de CV

P: 52 55 58 09 56 40 (DF y Area metropolitana)
P: 01 800 000 ASCO (2726) (Interior de la República)
F: 52 55 58 09 56 60

Brazil Ascoval Ind.e Comercio Ltda

P: (55) 11-4208-1700
F: (55) 11-4195-3970